

Optimization of Cornell L0 injector

T. Miyajima

KEK-PF, LEPP/Cornell University

13 May, 2008

L0 Beam Line

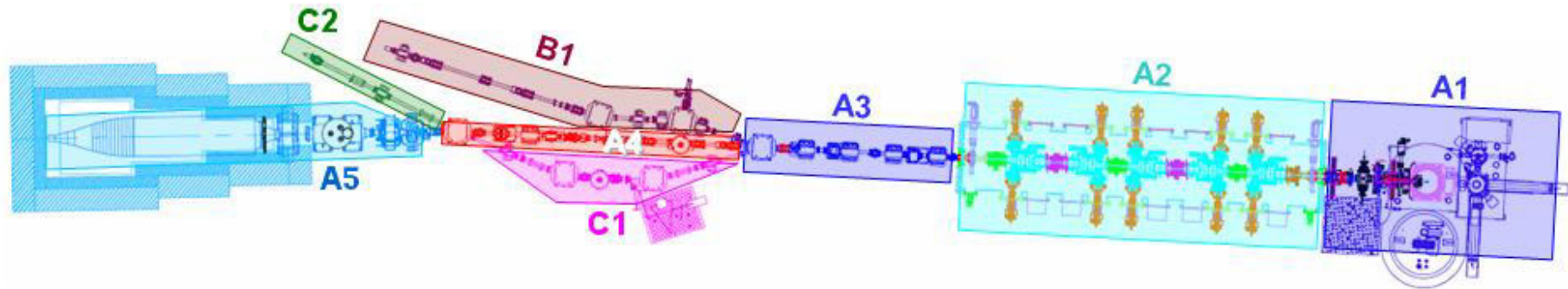

<https://wiki.lepp.cornell.edu/lepp/bin/view/ERL/Private/ErL0Beamline>

A1 - Gun Area
A2 - Cryomodule Area
A3 - Four-Quad Telescope
A4 - Straight-Through Chicane Section
A5 - Dump Area
B1 - Merger Line
C1 - Chicane Area
C2 - Offshoot Line Before Dump

- Now constructing...

- Photo cathode DC gun
- 5 SRF cavities
- 4 quadrupoles
- 3-dipoles merger
- Chicane
- Beam dump

Simulations

- Optimizations of ERL injector
- Modifying space charge program for merger simulation
- Minimum emittance in merger section
- New CSR code in particle tracking simulation
- Optimization of DC gun and SRF gun shapes

Optimizations of ERL injector

- “Multi-objective method” + “genetic algorithm” developed by I. Bazarov.
- Simulation code: Astra, Parmela and GPT
- Beam line: L0 beam line
 - DC gun
 - Solenoid
 - Buncher
 - Solenoid
 - 2 cell*5 SRF cavities
- Initial distribution: beer-can distribution
- Response time is zero (no tail).

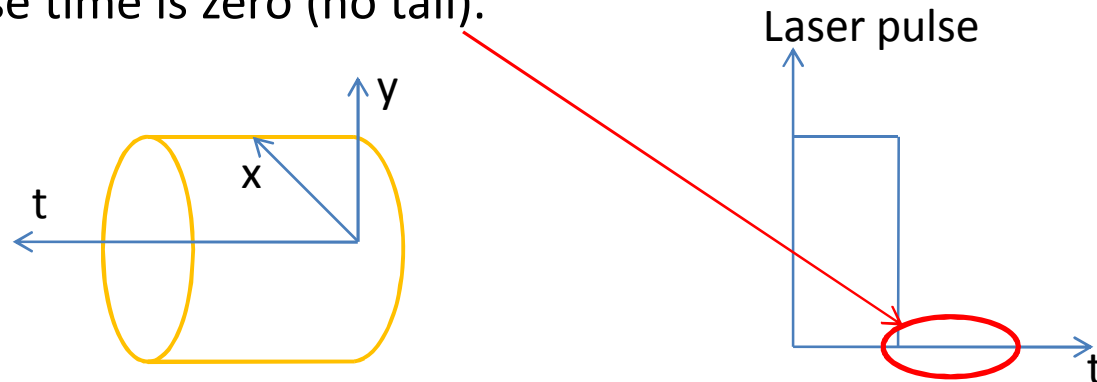

11 parameters

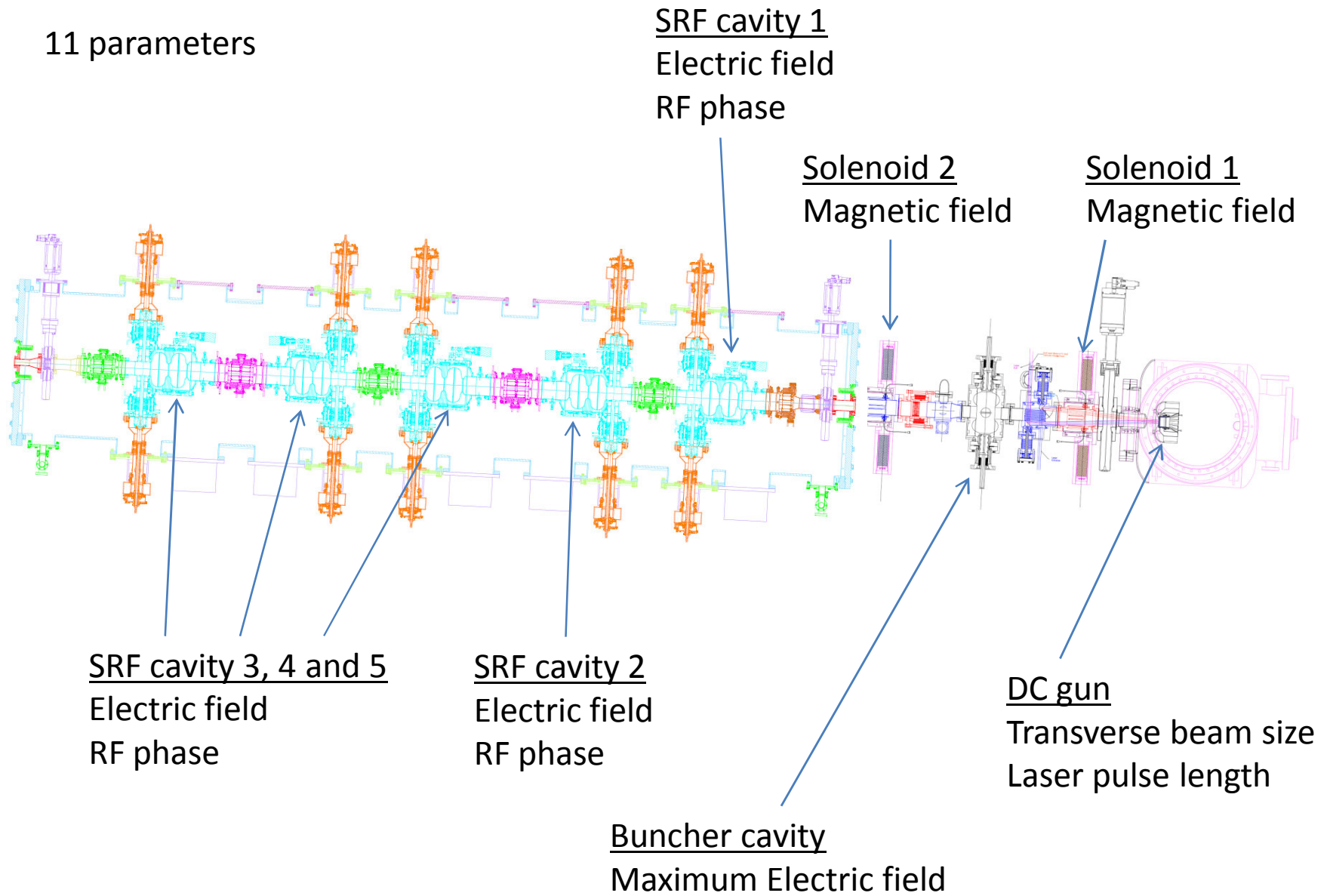

SRF cavity 1
Electric field
RF phase

Solenoid 2
Magnetic field

Solenoid 1
Magnetic field

SRF cavity 3, 4 and 5
Electric field
RF phase

SRF cavity 2
Electric field
RF phase

Buncher cavity
Maximum Electric field

DC gun
Transverse beam size
Laser pulse length

Multi-objective method

- Two objectives
 - For example, transverse emittance vs. bunch length

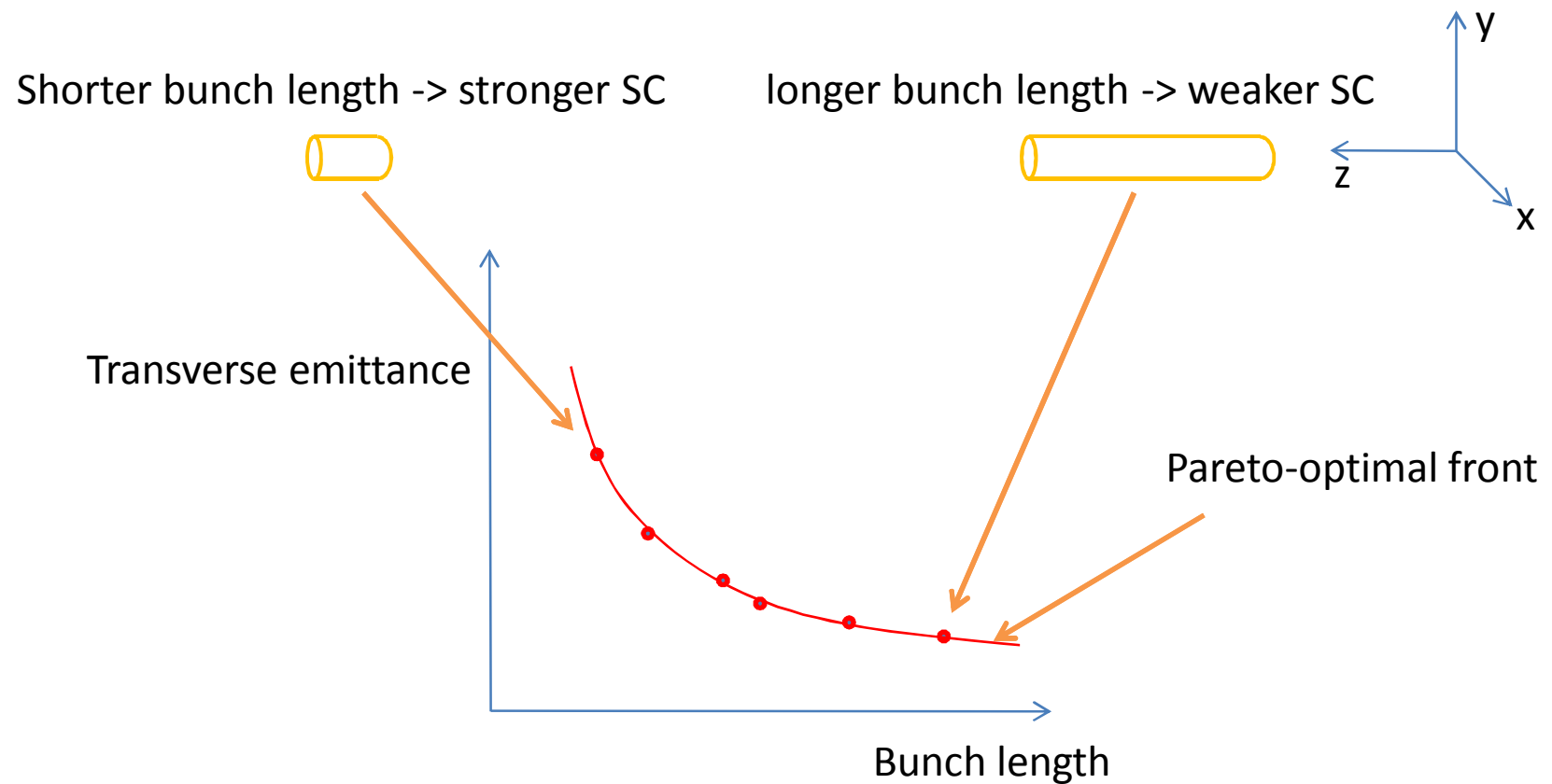

Simulation on a cluster computer on LEPP/Cornell

- Simulation code: Astra, GPT
- Cluster computer: “Feynman cluster”
 - OS: Linux
 - CPU: AMD Athlon(tm) MP 2400+ (dual CPU)
 - Number of computers: “compute-0-1” to “compute-0-99” (now, 71 computers are available.)
- Settings for multi-objective optimization
 - Number of populations: 50
 - Number of maximum generation: 200
- Example of CPU time
 - Average CPT time per 1 generation: 3.5 min (for nps=2k)
 - Total CPU time: 706 min

Parameter set 1
Beam size(1), solenoid(1),
buncher(1), ...

Parameter set 2
Beam size(2), solenoid(2),
buncher(2), ...

Parameter set 50
Beam size(50), solenoid(50),
buncher(50), ...

Emittance(1), stdz(1) ...

Emittance(2), stdz(2) ...

Emittance(50), stdz(50) ...

Transverse emittance

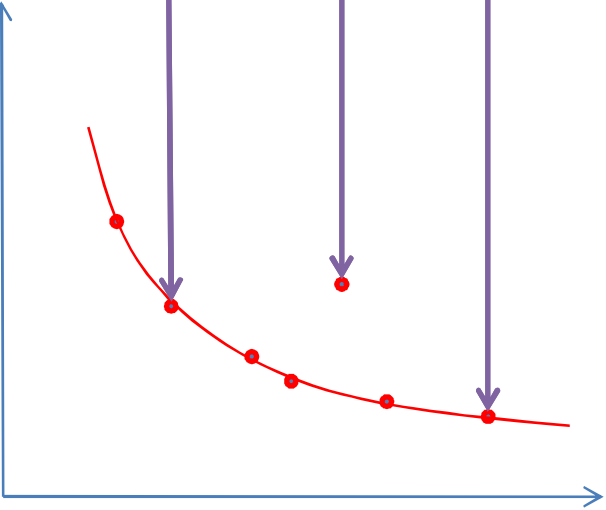

Bunch length

Initial parameters

- DC gun voltage: 500 kV
- $kT = 115$ meV
- 77 pC / bunch
- Objectives
 - Bunch length at a slit
 - Transverse emittance at a list
- Initial particle distribution
 - Transverse direction: radial uniform
 - Longitudinal: uniform

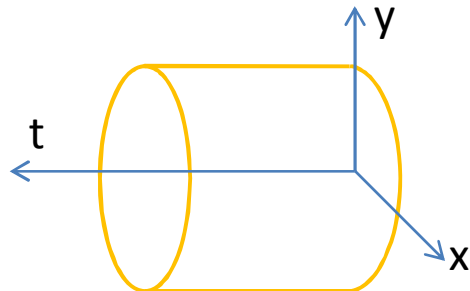

- Decisions

Decision variable	range
Initial laser pulse width	2 to 30 ps
Initial Transverse beam size	0 to 2 mm
Solenoid 1	0 to 0.1 T
Solenoid 2	0 to 0.1 T
Buncher field	0 to 10 MV/m
First cavity field	10 to 30 MV/m
Second cavity field	10 to 30 MV/m
Third to fifth cavity field	10 to 30 MV/m
First cavity offset	-60 to 10 degree
Second cavity offset	-60 to 10 degree
Third to fifth cavity field	-30 to 10 degree

Transverse emittance at a slit

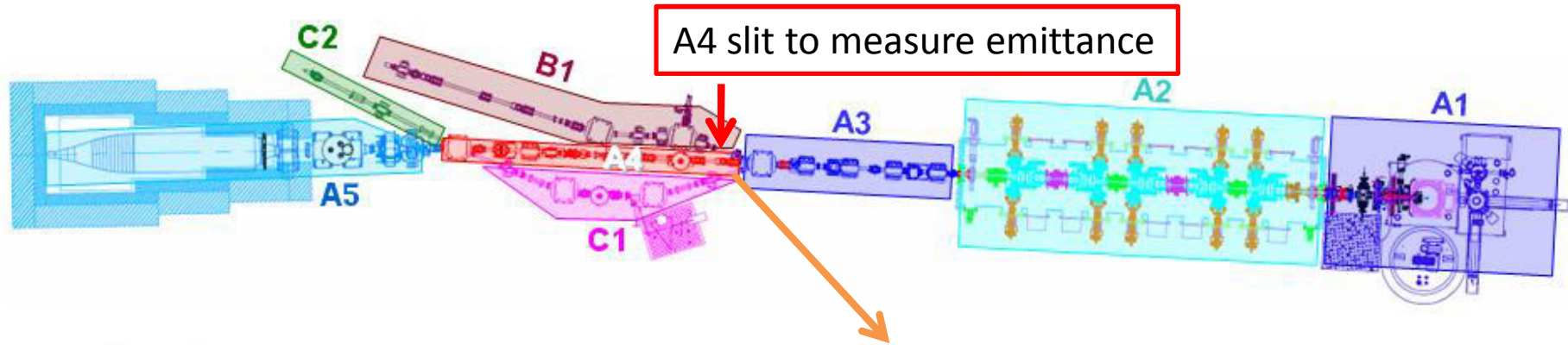

- A1 - Gun Area
- A2 - Cryomodule Area
- A3 - Four-Quad Telescope
- A4 - Straight-Through Chicane Section
- A5 - Dump Area
- B1 - Merger Line
- C1 - Chicane Area
- C2 - Offshoot Line Before Dump

Cornell L0 beam line, $kT=115\text{meV}$, 500kV DC gun

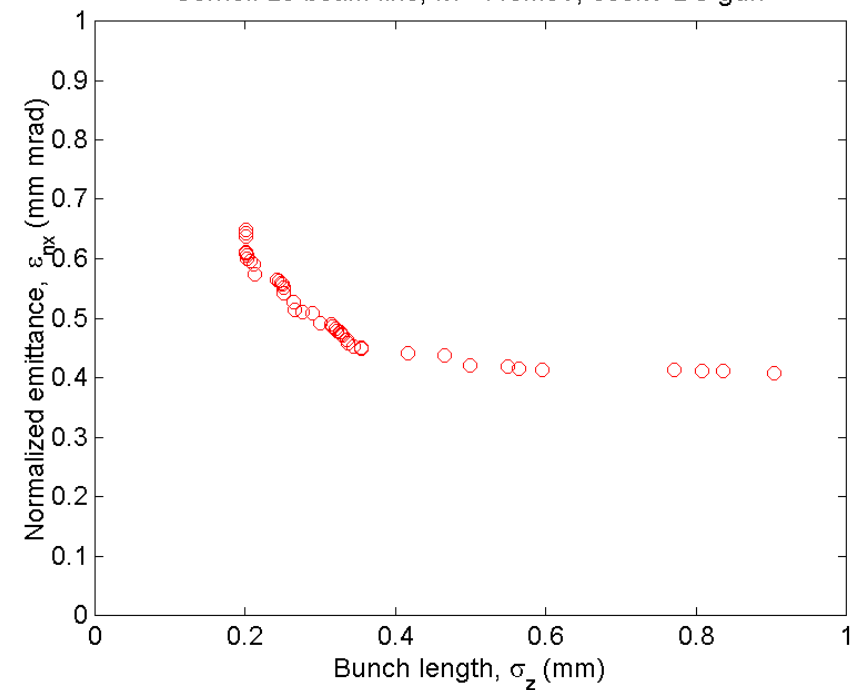

Time evolution of emittance

- Stdz = 0.3, 0.6 and 0.9 mm

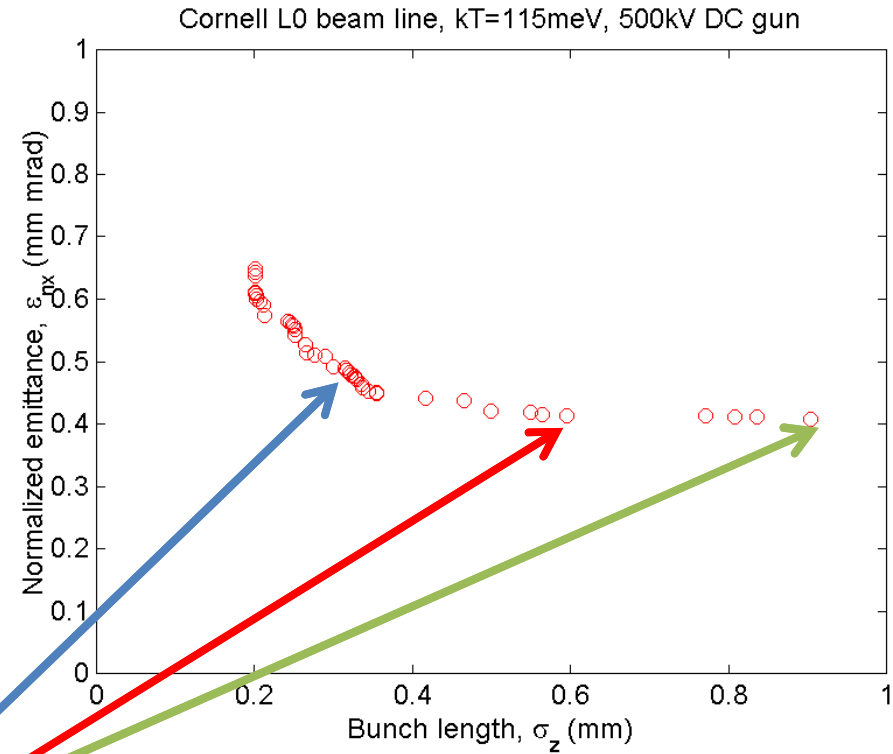
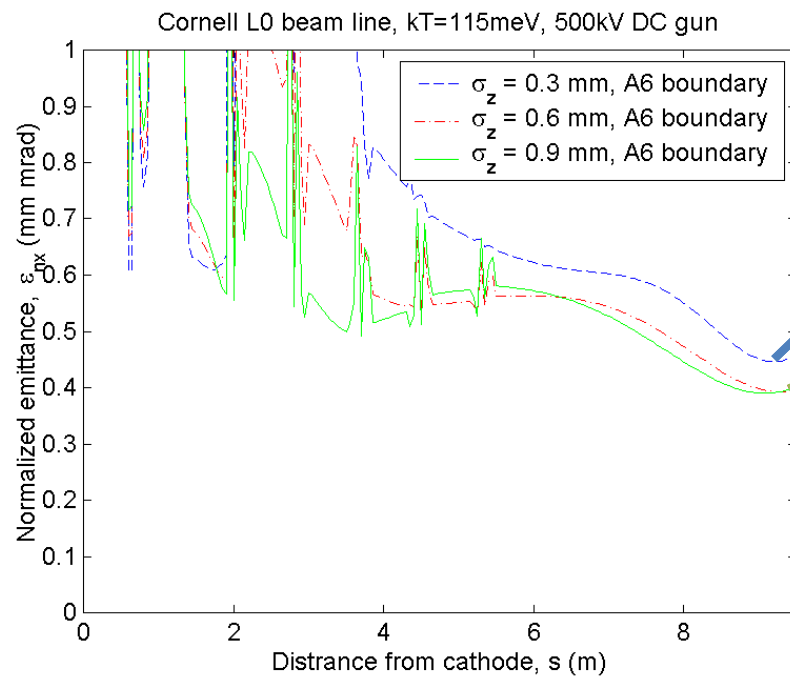

Gun and buncher area

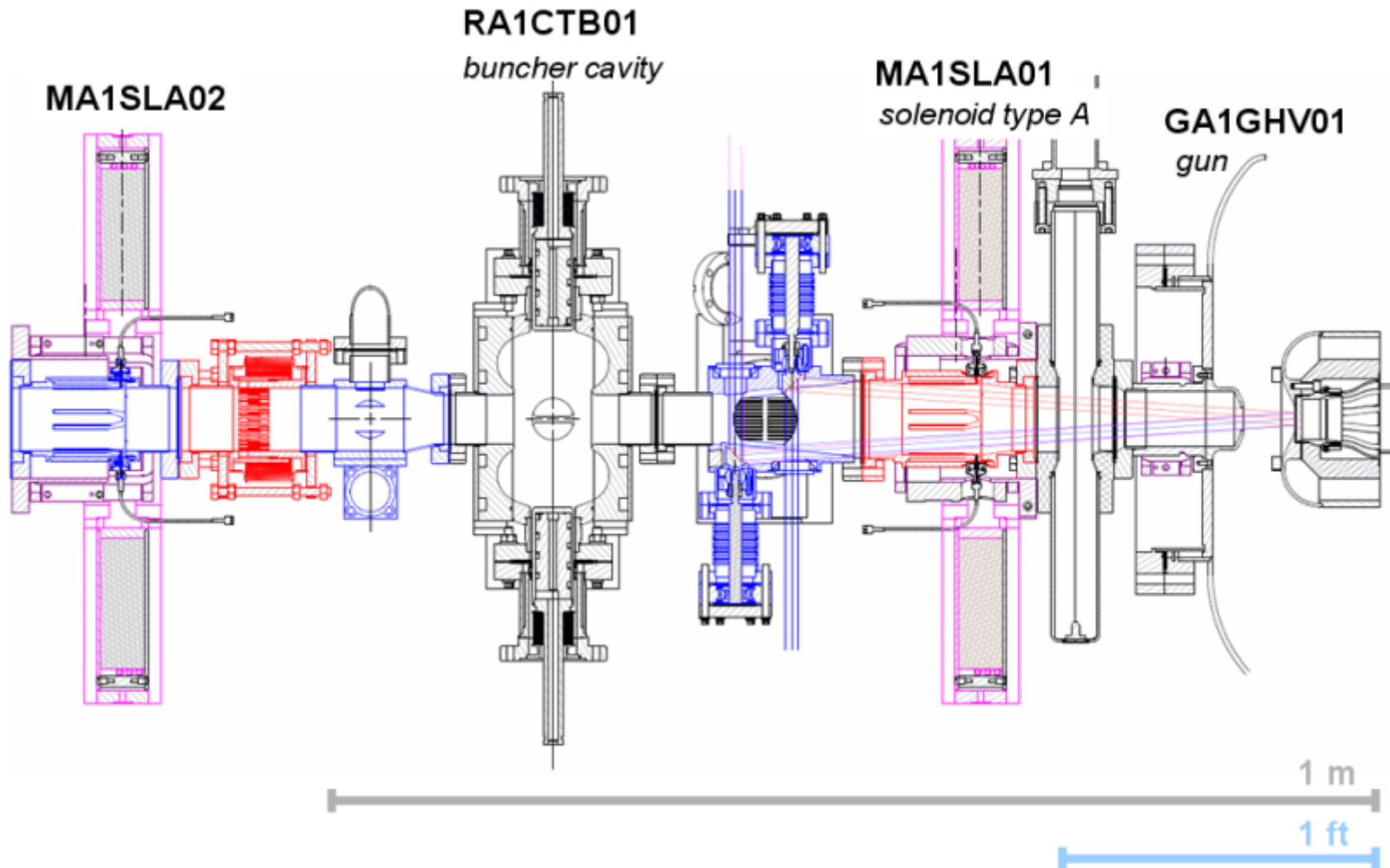

Initial laser pulse and beam size

- Initial laser pulse
 - 2 to 30 ps

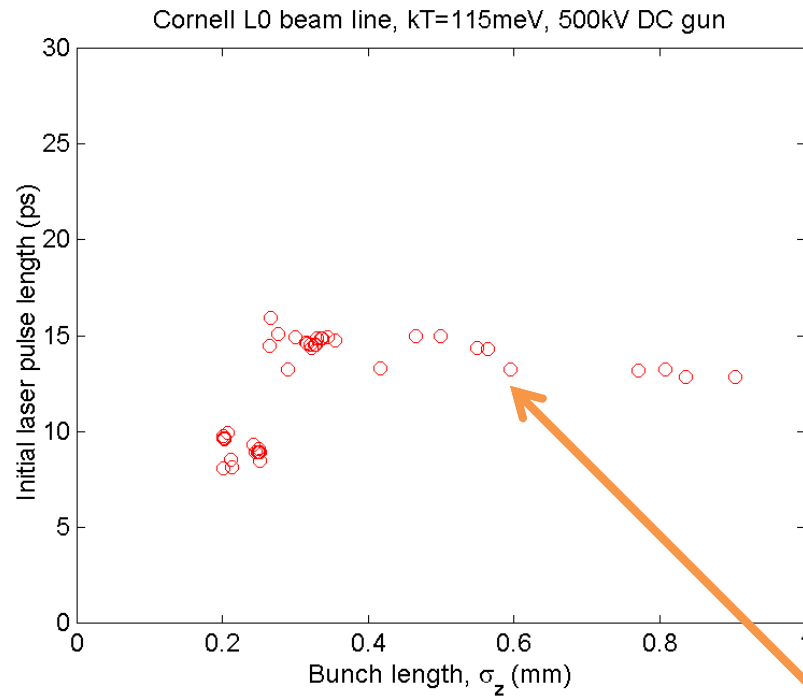

- Initial transverse beam size
 - 0 to 2 mm

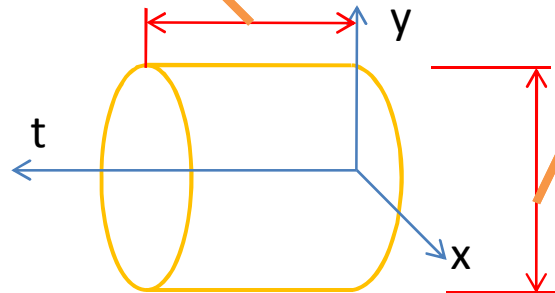
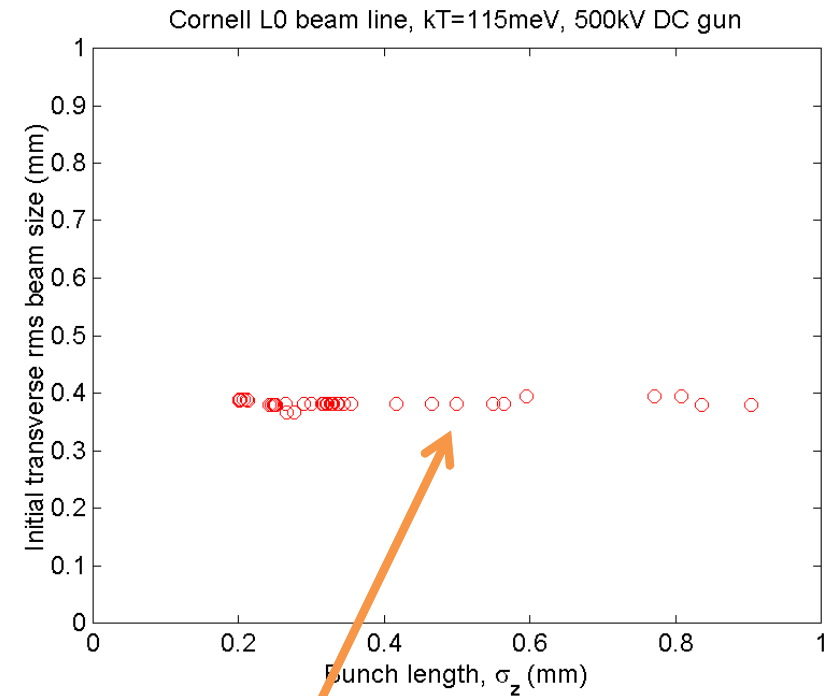

Solenoid strengths

- Solenoid 1 and 2
– 0 to 0.1 T

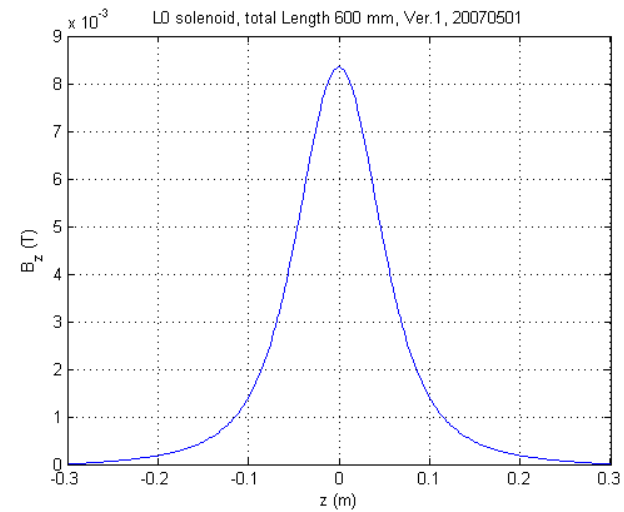
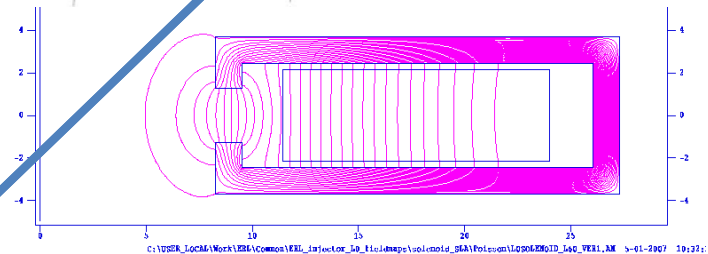
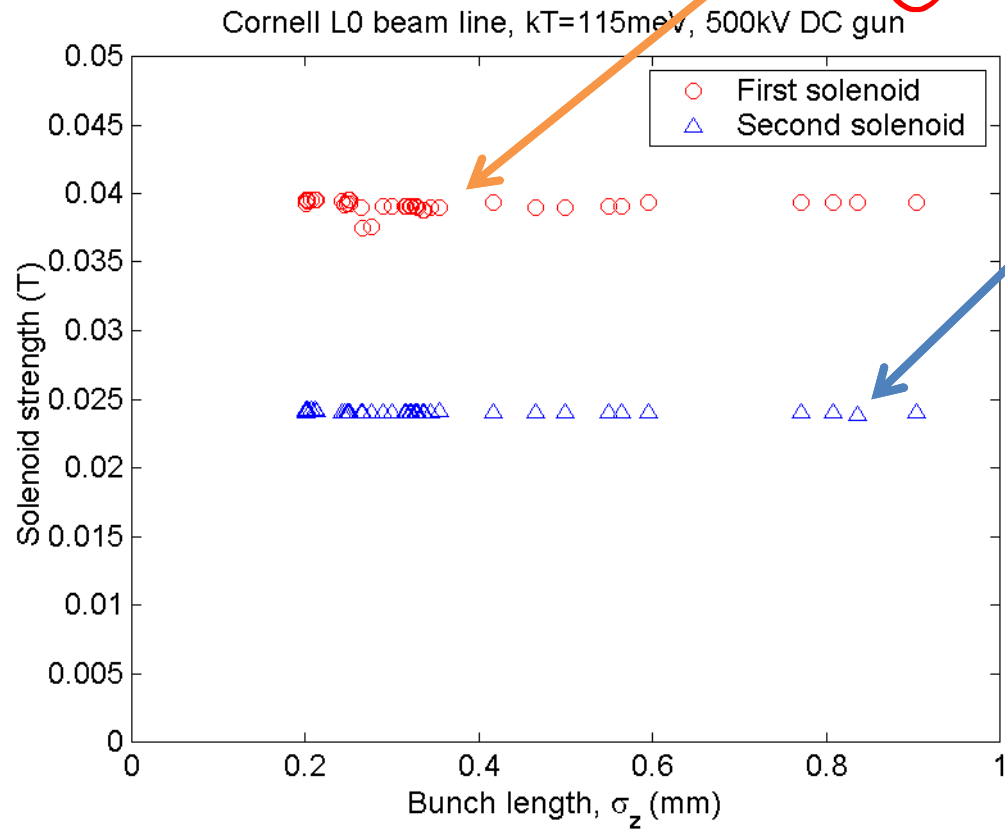
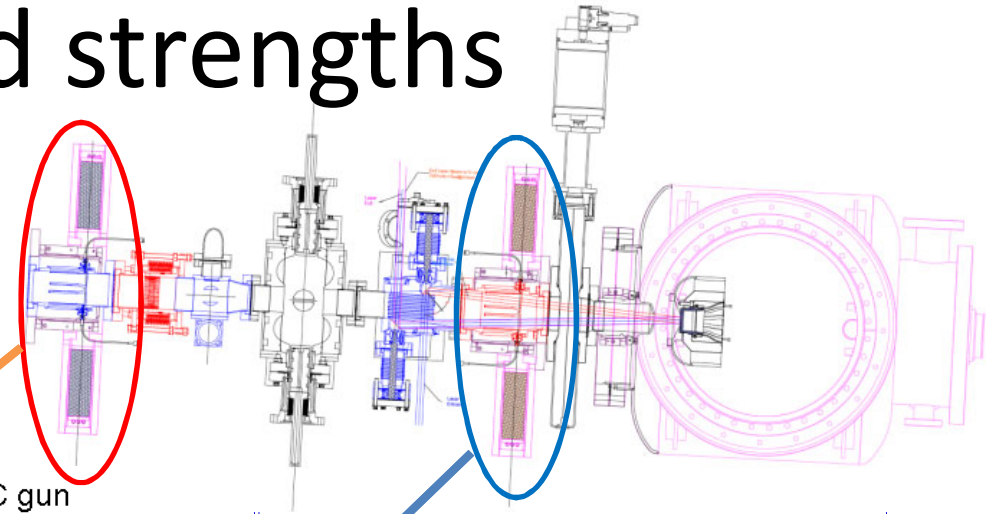

Buncher cavity field

- Buncher
– 0 to 10 MV/m

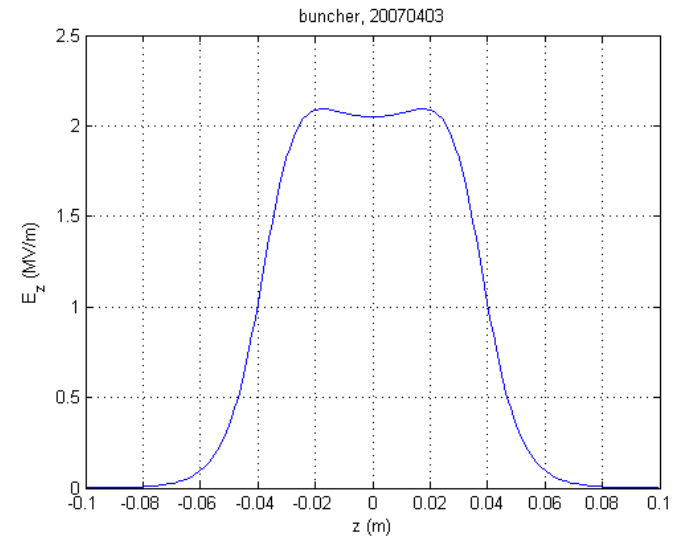
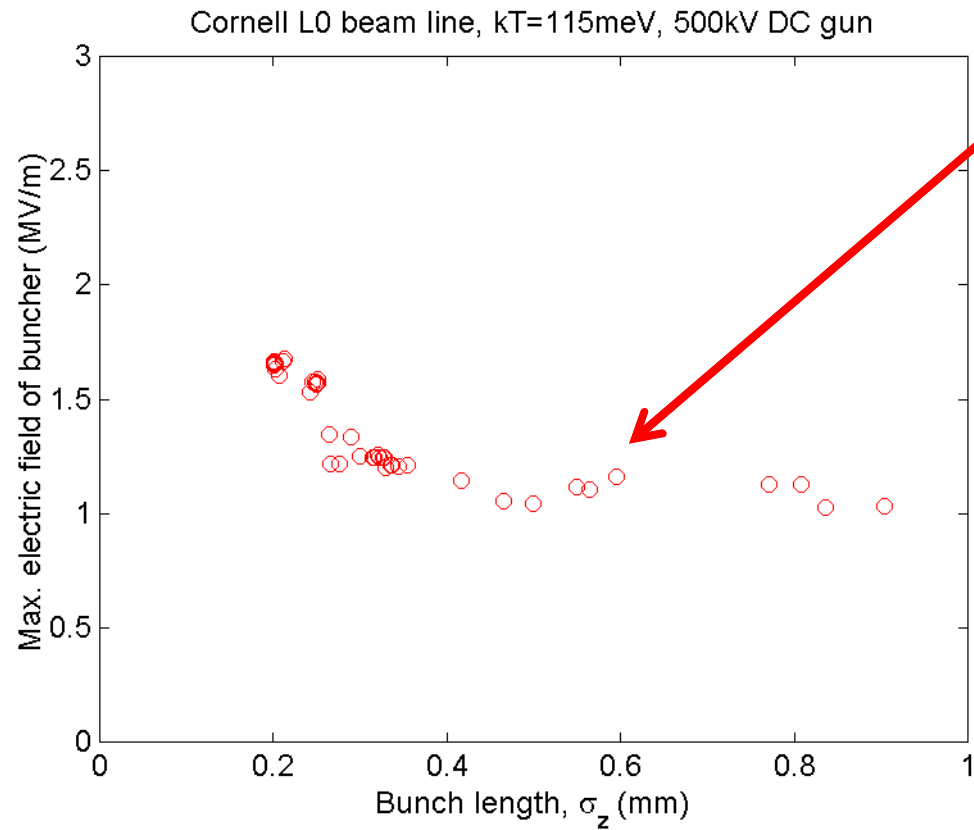
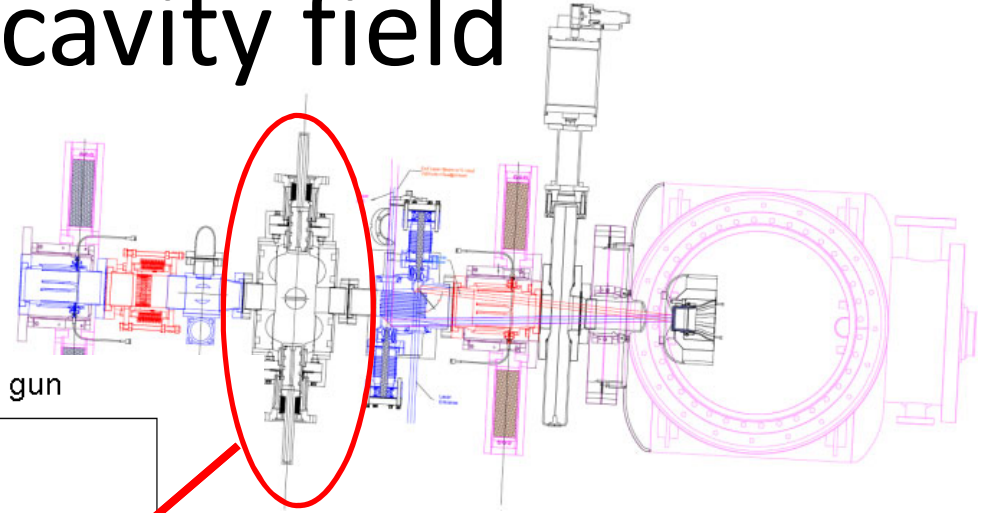

SRF cavities

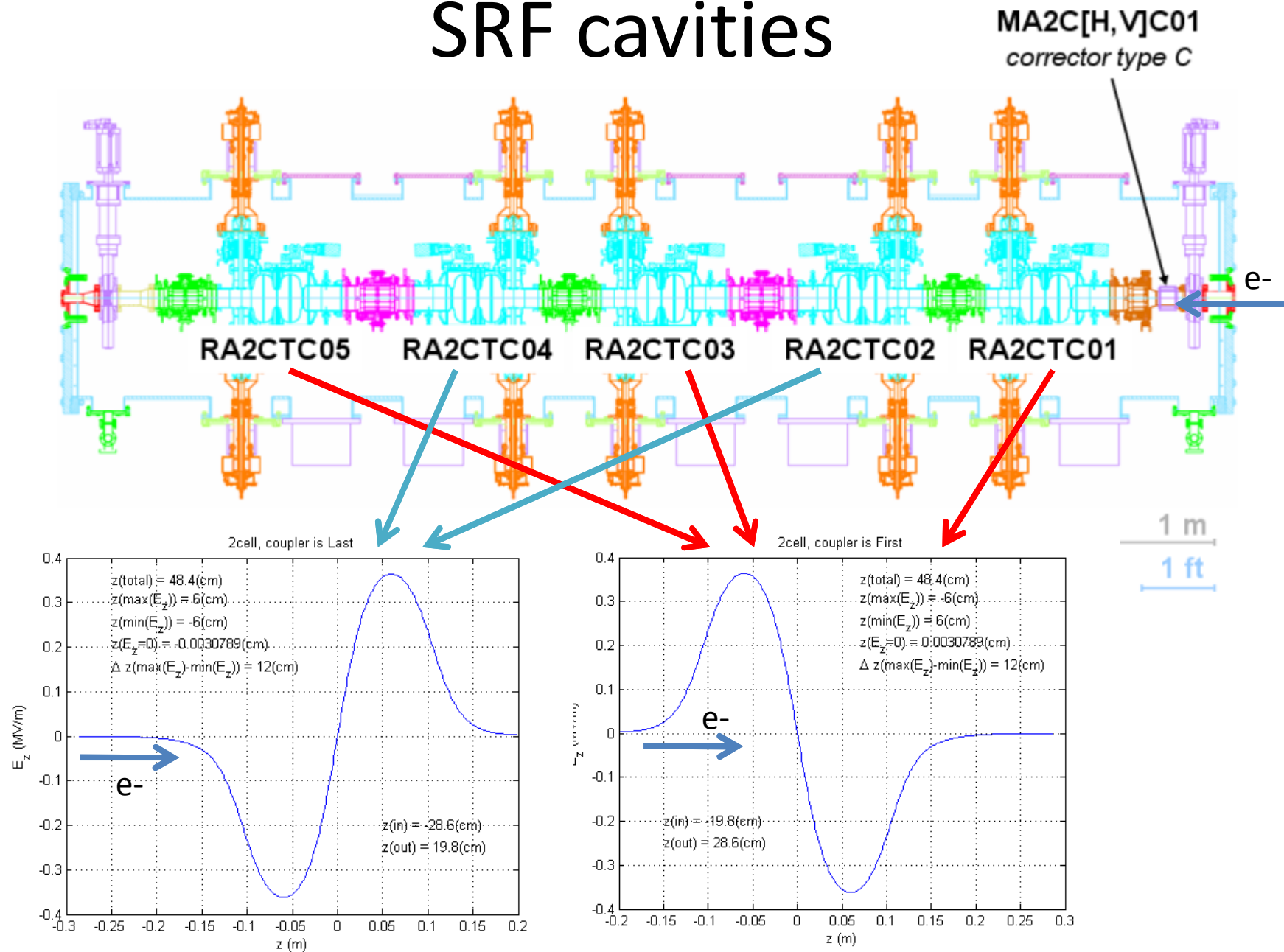

SRF cavity fields and phases

- Maximum fields

- 1st cavity: 10 to 30 MV/m
- 2nd cavity: 10 to 30 MV/m
- 3rd to 5th cavity: 10 to 30 MV/m

- Phase offset

- 1st cavity: -60 to 10 degree
- 2nd cavity: -60 to 10 degree
- 3rd to 5th cavity: -30 to 20 degree

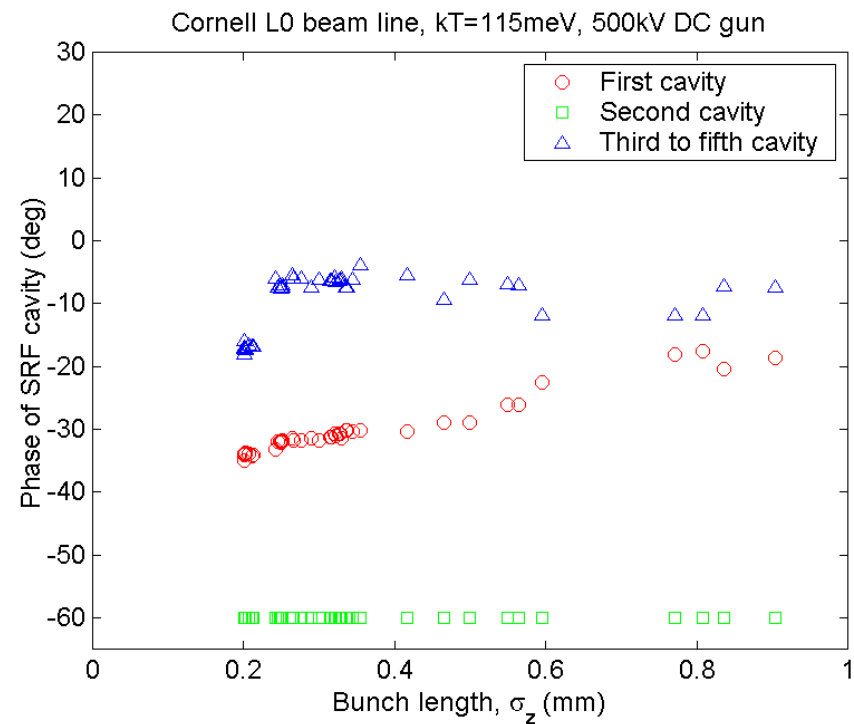
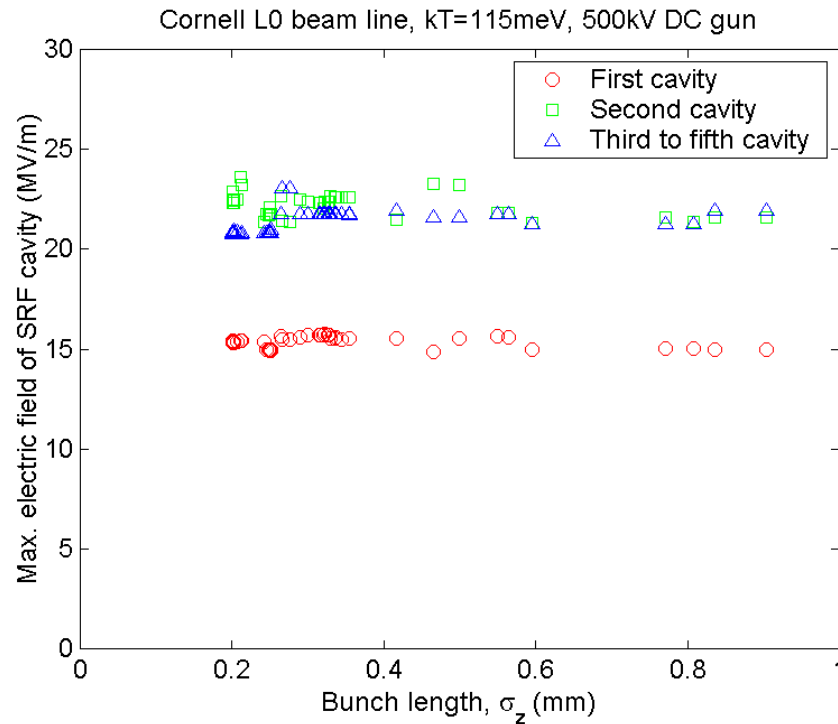

- Stdz = 0.9 mm

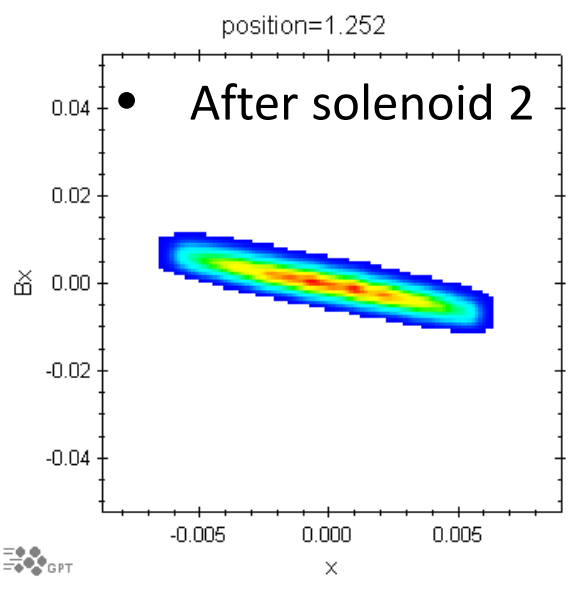
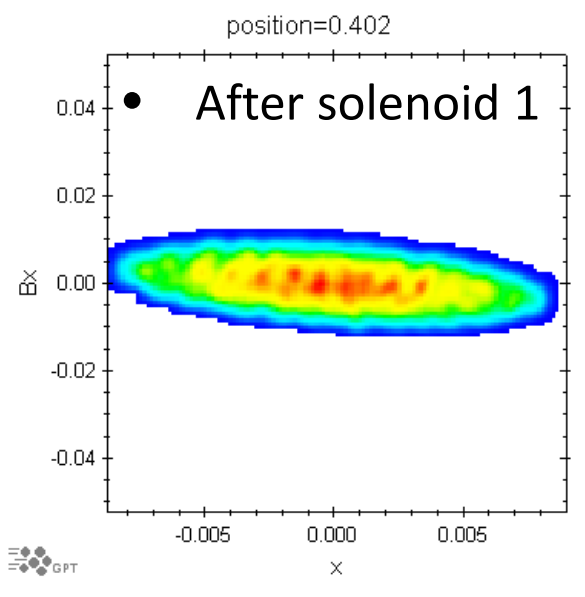
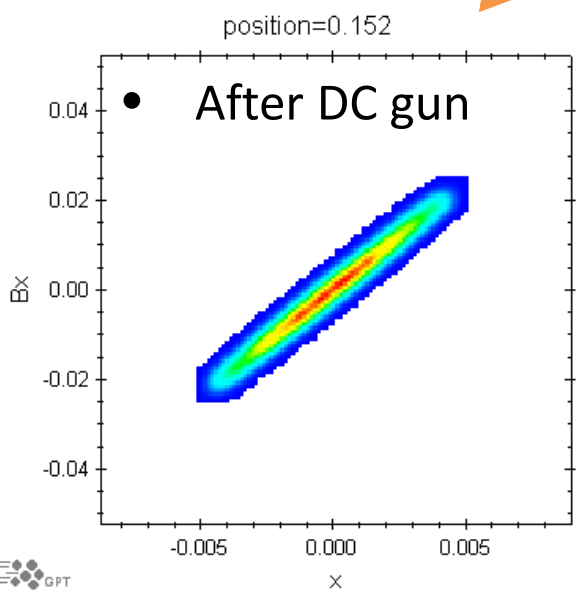
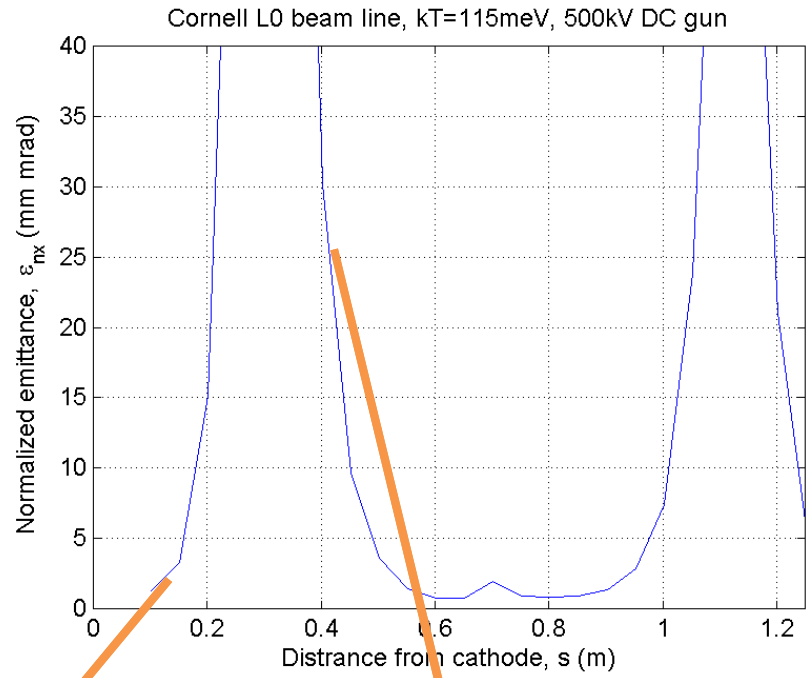

- Stdz = 0.9 mm

Cornell L0 beam line, kT=115meV, 500kV DC gun

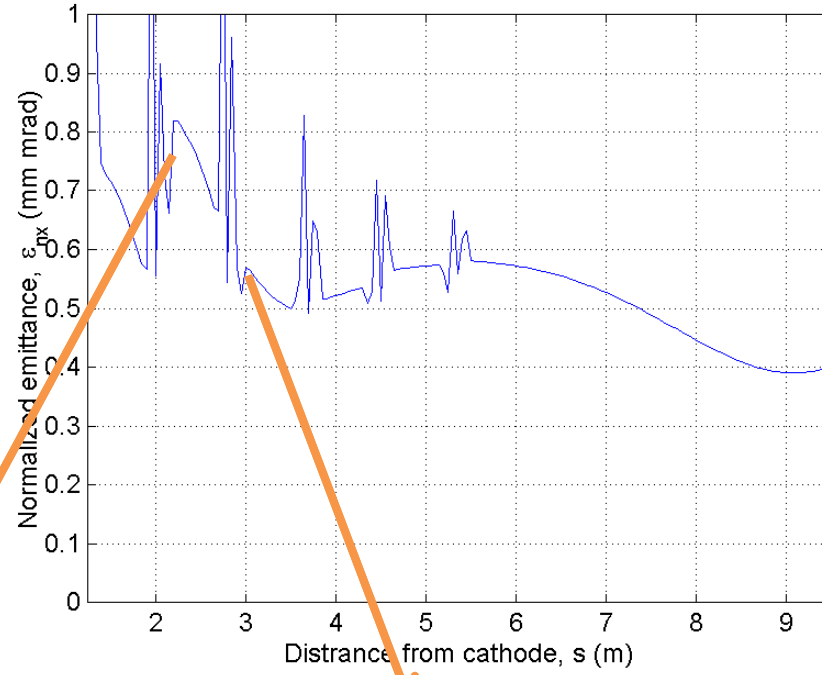

position=2.252

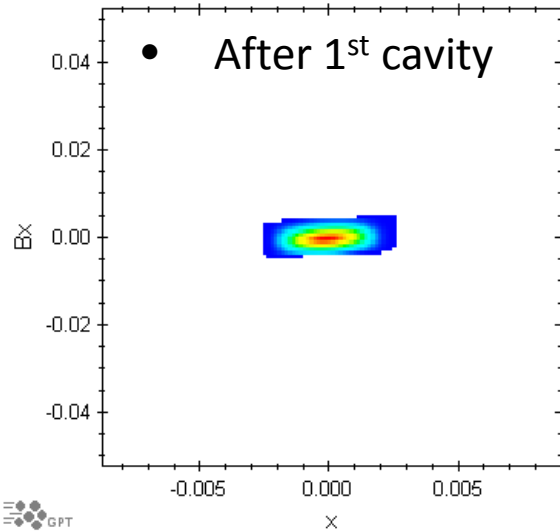

position=3.052

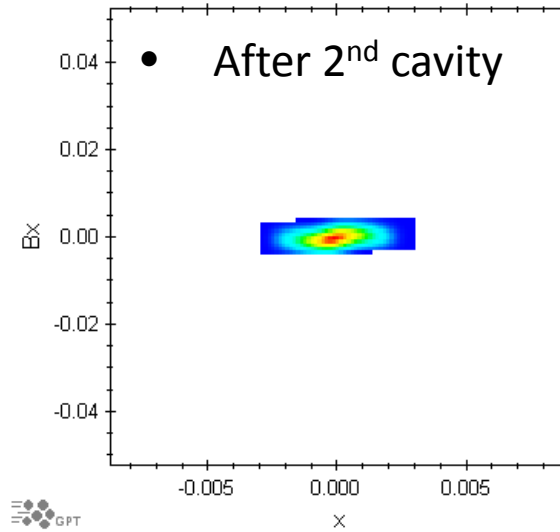

position=9.452

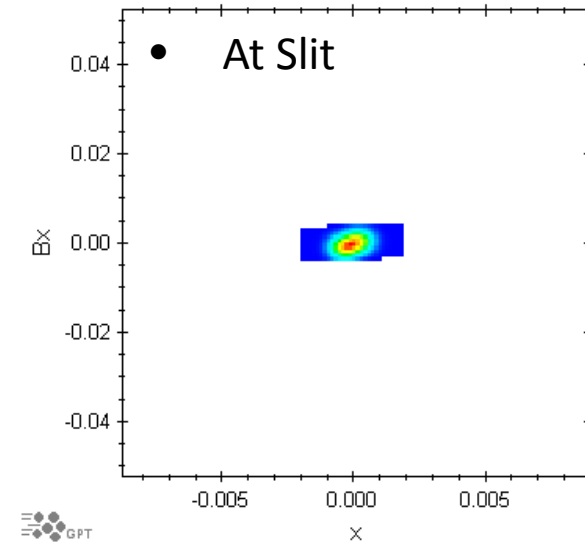

Optimum parameters for L0 beam line with 500 kV DC gun and $kT = 115$ meV

- Initial beam size
 - Laser pulse width: 10 to 15 ps
 - Transverse rms beam size: 0.4 mm
- Solenoid strengths
 - 1st solenoid: 0.025 T
 - 2nd solenoid: 0.04 T
- Buncher field
 - 1 to 1.5 MV/m

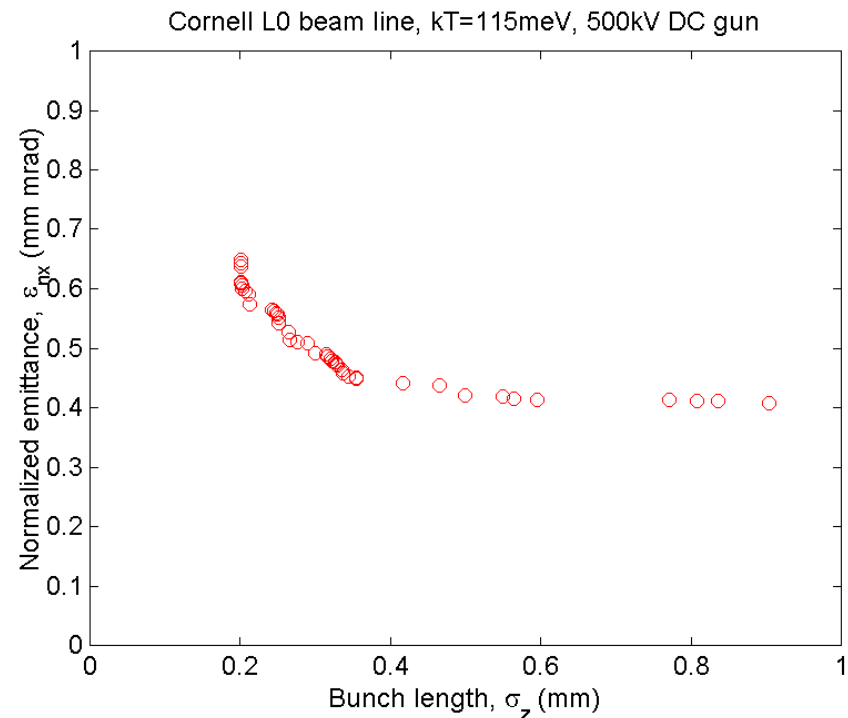

- 1st SRF cavity
 - Maximum field: 15 MV/m
 - Offset phase: -35 to -20 degree
- 2nd SRF cavity
 - Maximum field: 22 MV/m
 - Offset phase: -60 degree
- 3rd to 5th SRF cavities
 - Maximum field: 22 MV/m
 - Offset phase: -10 to -5 degree

