

# Approach to a Start-to-End simulation of 2-Loop compact Energy Recovery Linac

M. Shimada<sup>A)</sup>, T. Miyajima<sup>A)</sup>, N. Nakamura<sup>A)</sup>, Y. Kobayashi<sup>A)</sup>, K. Harada<sup>A)</sup>, S. Sakanaka<sup>A)</sup>, R. Hajima<sup>B)</sup>

<sup>A)</sup>High Energy Accelerator Research Organization, KEK

<sup>B)</sup>Japan Atomic Energy Agency, JAEA

- 
1. Background, Layout and Beam dynamics
  2. Results

## Multi GeV ERL and Compact ERL

- **Multi-GeV ERL and XFEL-O** are considered as a successor of Photon Factory of KEK.
- **The extreme low emittance beam** is necessary for both operation to achieve a high performance.

**Start-to-End (S2E) simulation is a strong tool**  
to clarify the beam dynamics of the low emittance beam.



R&D machine, 2 loop Compact ERL is under construction

R&D of S2E simulation is also started for Compact ERL.

# Double Loop Compact ERL

- Why did we choose a double loop circulator?

It is for saving  
 construction area  
 number of accelerator cavities  
 running cost of the refrigerators

Injection energy	5- 10 MeV
Full energy	245 MeV
Electron charge	77 pC
Normalized emittance	< 1 mm-mrad
Bunch length	1-3 ps

Main parameters

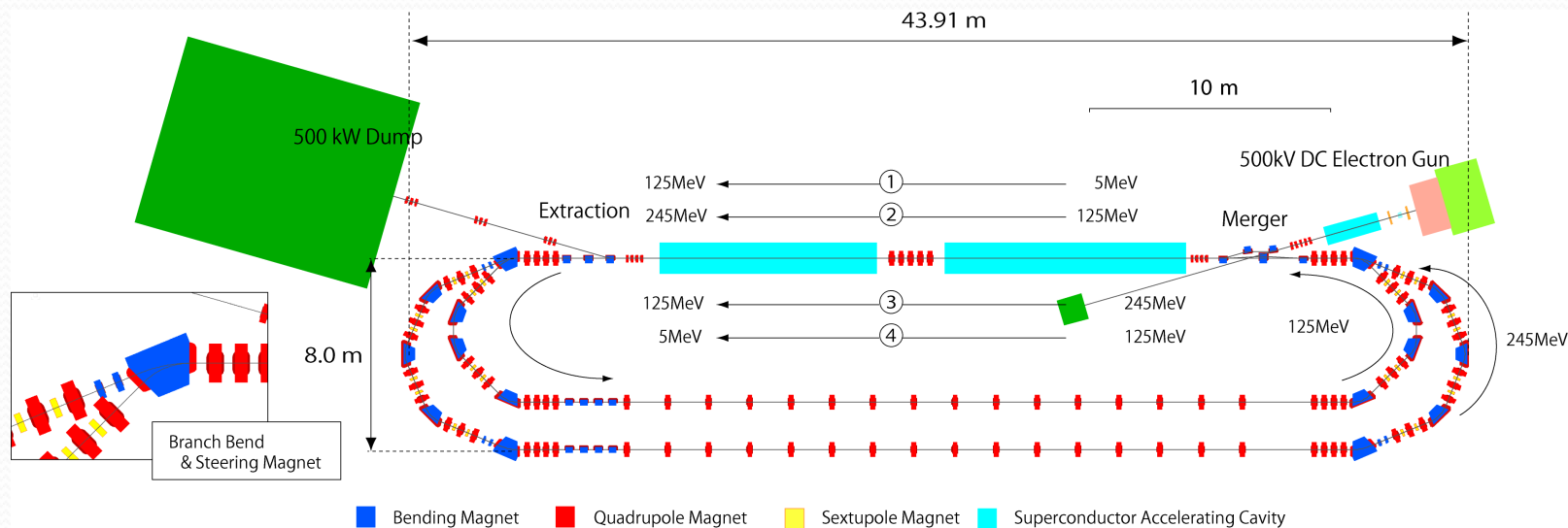

Layout of double loop Compact ERL

# Start-to-End (S2E) simulation for cERL (I)

S2E simulation : simulation code is switched by stages of accelerator.  
(e.g., injector, circulator, FEL)

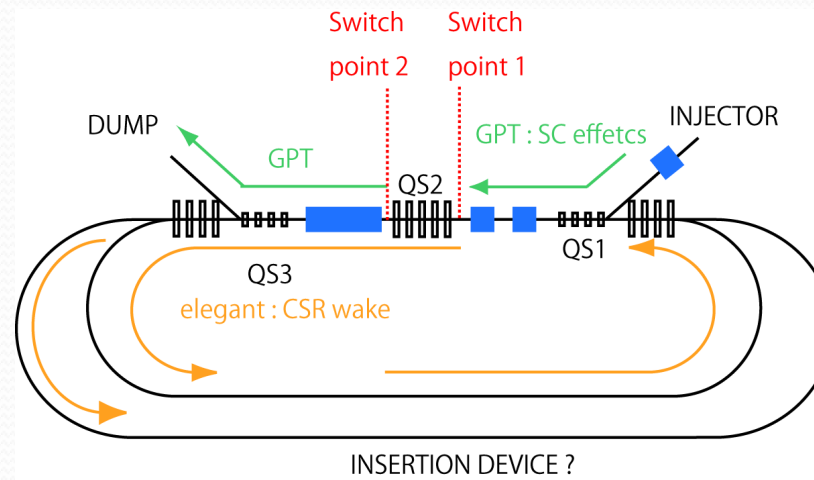

To evaluate the emittance growth due to space charge (SC) effects and CSR wake

- Low energy region ( < 65 MeV ) , Injector and deceleration  
General Particle Tracer (GPT) : including SC effects,  
ignoring CSR wake to save CPU time, **not fast**
- High energy region ( > 65 MeV), 2 loop circulator  
'elegant' : lacking SC effects, including 1D transient CSR wake, **fast**

# S2E simulation for cERL (II)

## Goal

- Transport beam with the low emittance to the insertion device in outer loop
- Transport beam to the dump with reasonable beam size

## • S2E simulation with iteration

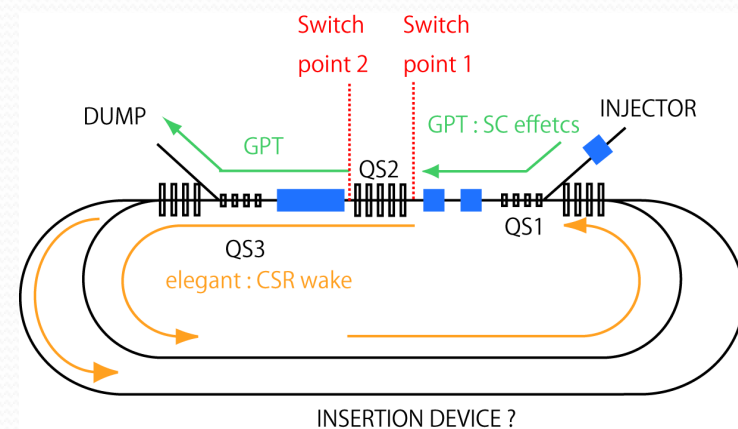
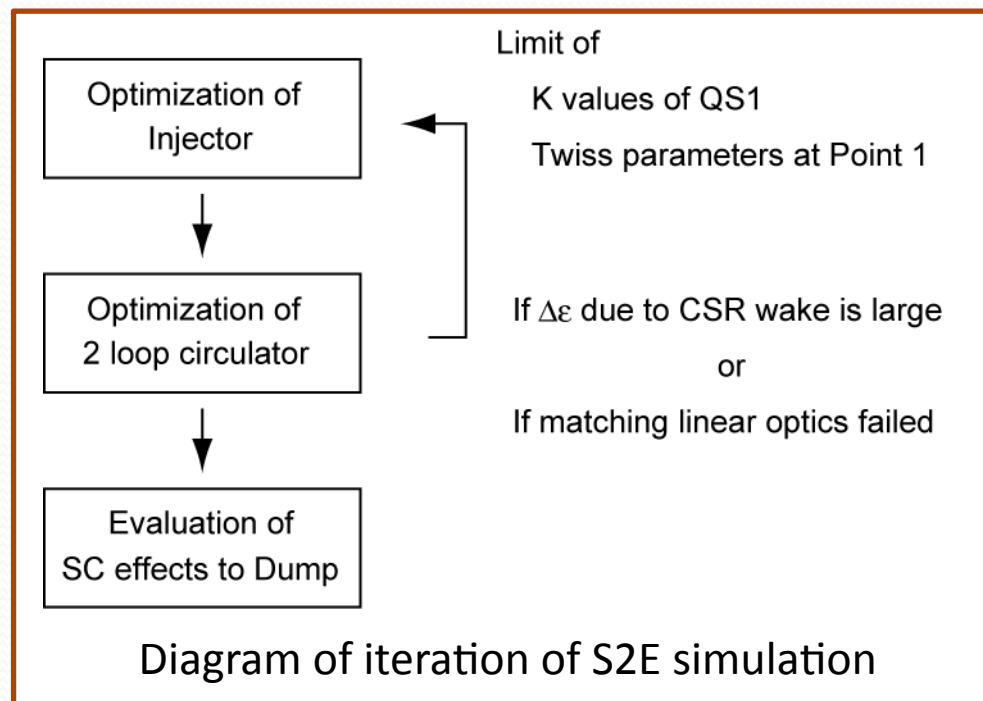

The 6D distribution data is passed from the electron gun to the dump (self-consistent)

# Layout and optimization of injector

## 1. Minimization of emittance

**Two solenoids and five quadrupole magnets**

are used for compensation of the emittance growth

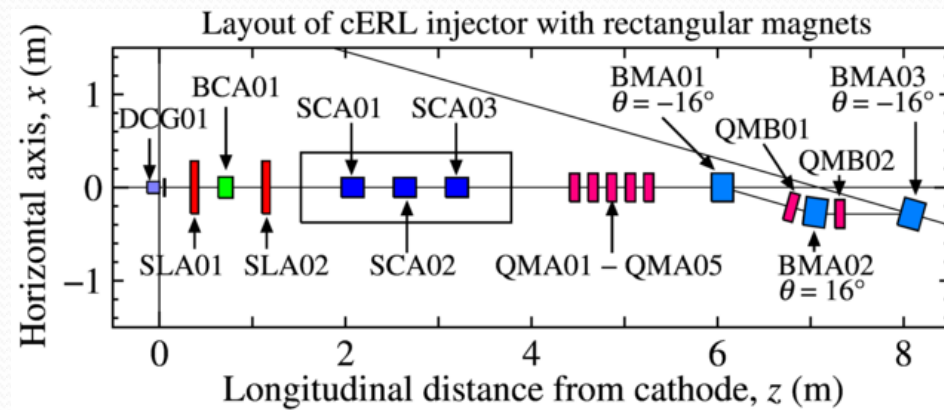

## 2. Matching with circulator loops

**Four quadrupole magnets**

are used for matching Twiss parameters

Point A2 : Switching point, 65MeV

Target of Twiss parameters

$$\beta_x, \beta_y < 100 \text{ m}, -2 < \alpha_x, \alpha_y < 2$$

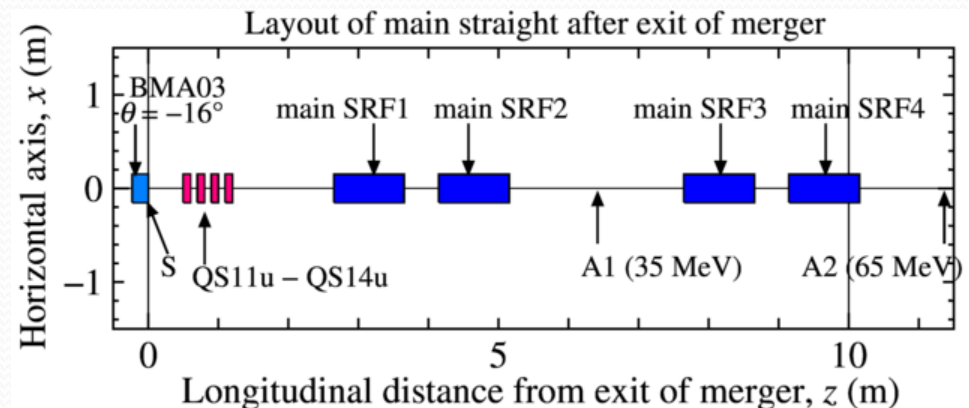



# Emittance growth due to space charge effects

## Projected emittance growth

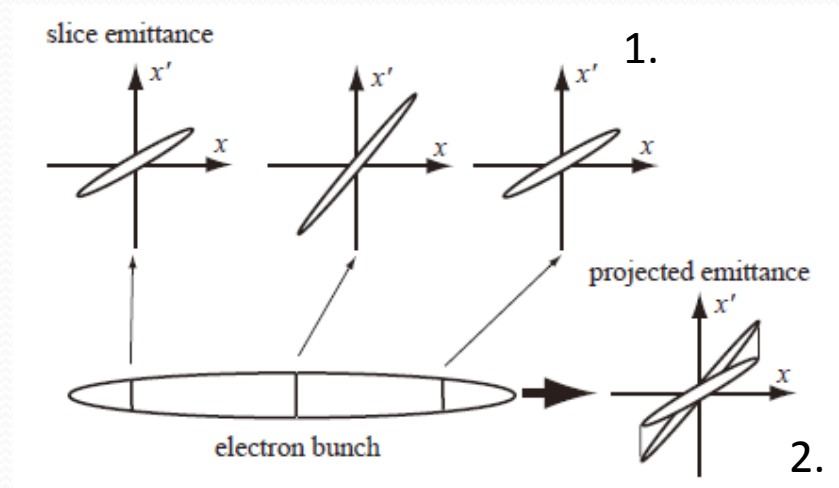

1. Defocusing force of the electron depends on the electron density.
2. The projected emittance increases if slice emittance depends on the longitudinal position.

## Compensation of emittance growth

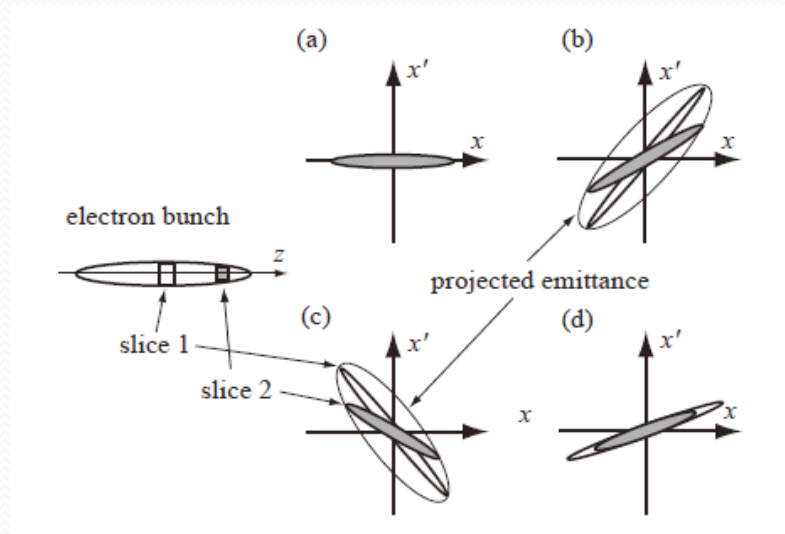

- Solenoids and quadrupole magnets are effective.
- Above schematic figure : Solenoid



# Simulation with GPT at injector

Beam energy	5 – 10 MeV
Beam current	10 – 100 mA (1.3 GHz)
Normalized rms emittance $\varepsilon_n = \varepsilon/(\gamma\beta)$	< 1 mm·mrad (77 pC/bunch)
Rms bunch length (rms)	1 – 3 ps (0.3 – 0.9 mm)

- ❑ Particle tracking code : GPT(General Particle Tracer)[1]
- ❑ Space charge calculation : 3D mesh based method
- ❑ Initial particle distribution : beer-can
- ❑ No CSR effect in merger section to save a CPU time
- ❑ Optimization performed by 2k particles to save a CPU time
- ❑ 6D distribution data of 100k particles is used for S2E simulation

[1] Pulsar Physics, <http://www.pulsar.nl/gpt/index.html>

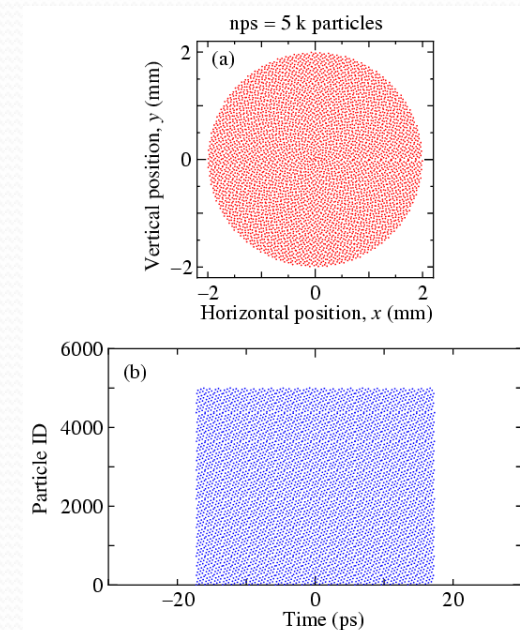

Initial distribution on cathode : beer-can

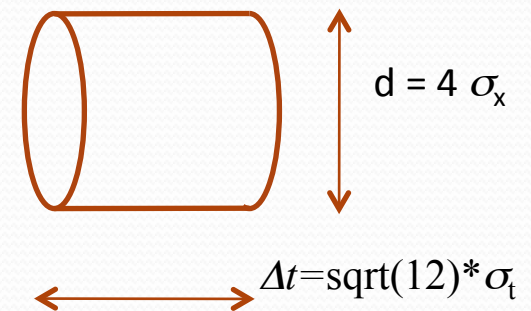

# Main linac of Double Loop Circulator

- Main linac : Two accelerator and two decelerator beams
- To make it easy to optimize the four beams at the same time,
  - Quasi-symmetric optics
  - Dummy Loop: Loops are replaced by 4 x FODO
- $Q$  for 5MeV also focus higher energv. 125 and 245MeV

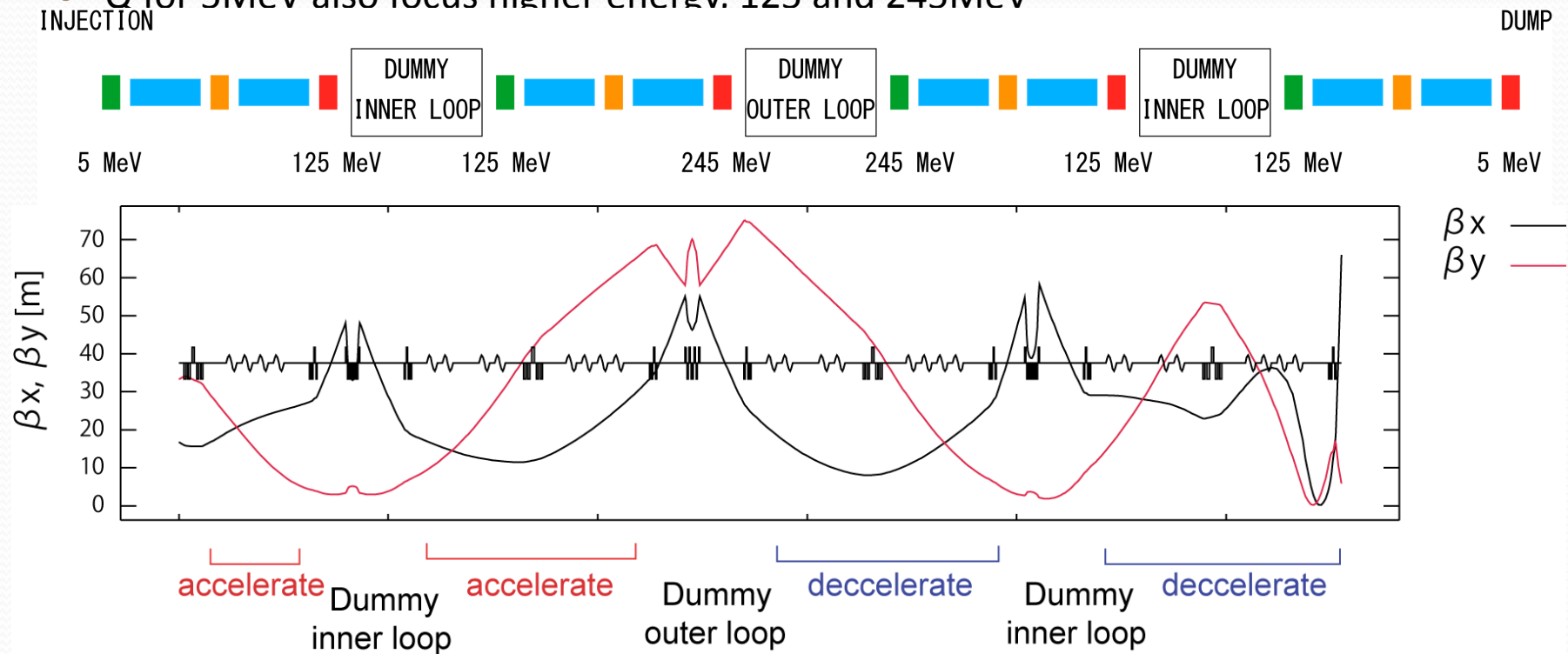
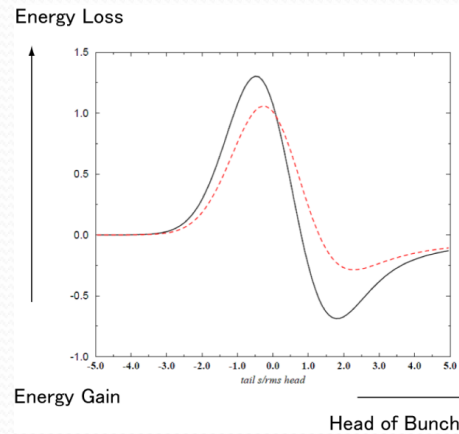
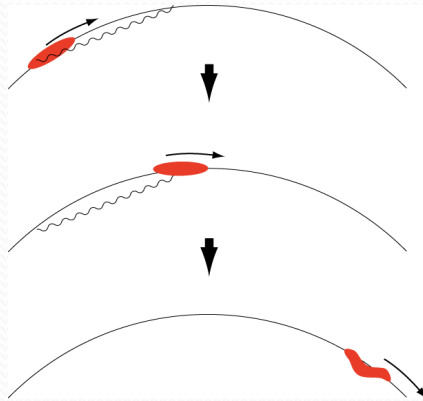
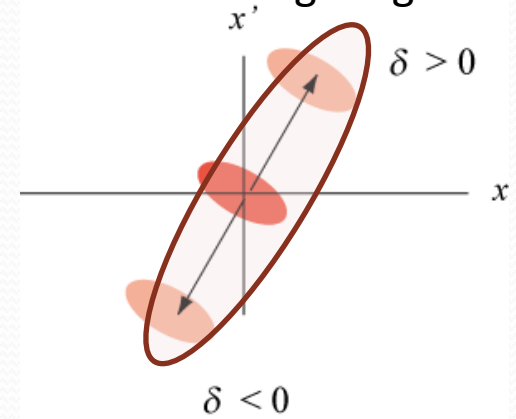

Fig. All accelerator and decelerator linear optics of 2-loop ERL with dummy loops

# Emittance growth due to CSR wake



## Exit of Bending Magnets



Energy distribution is distorted in bending magnet



Emittance growth

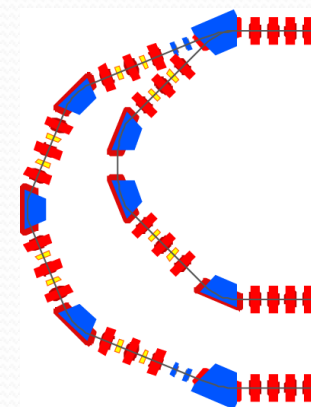
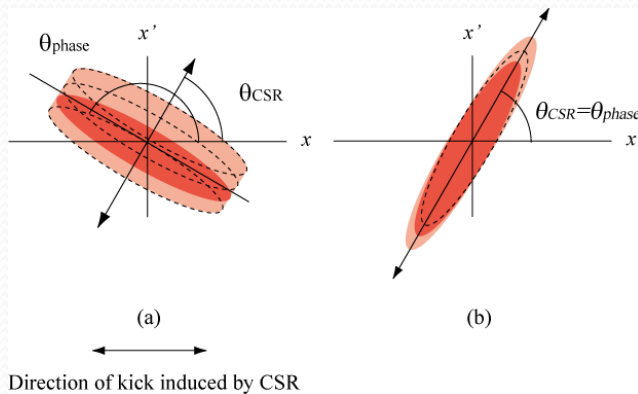

Phase matching is effective but...

Which bending magnet should be matched ?

It is difficult to analytically minimize the emittance growth.

- 
1. Background, Layout and Beam dynamics
  2. Results

# Optimization results of Injector

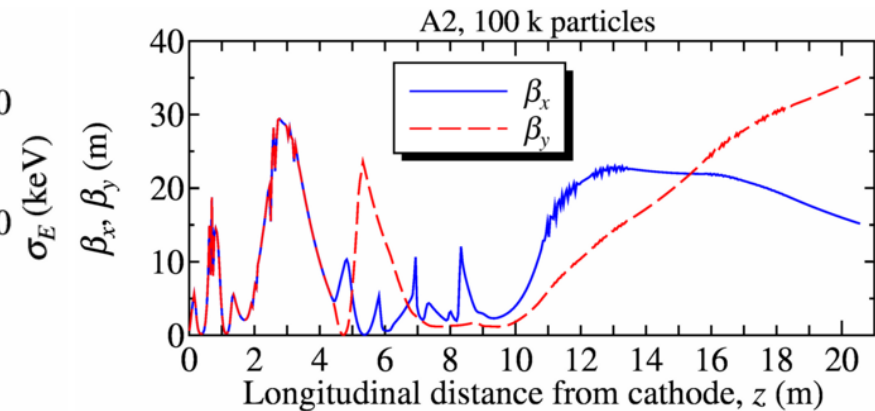
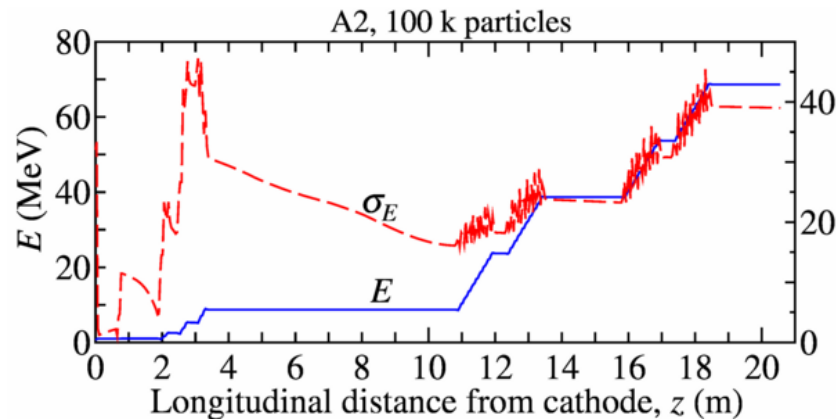
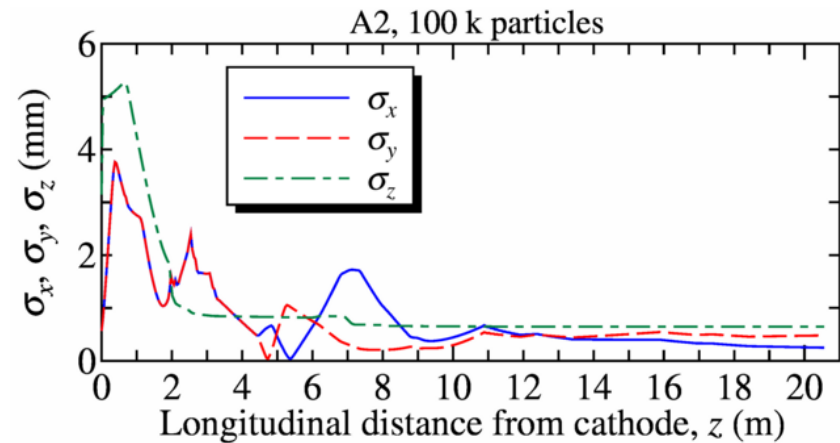
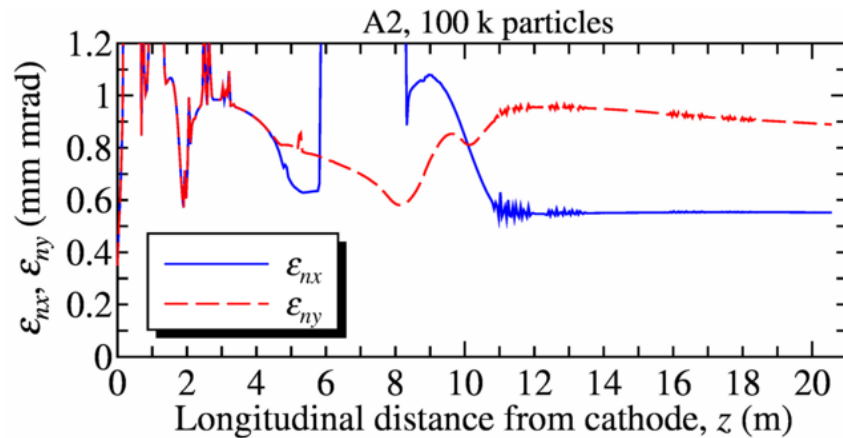

- $(\beta_x, \alpha_x, \beta_y, \alpha_y) = (16.7 \text{ m}, 0.83, 33.3 \text{ m}, -0.76)$ . The normalized emittances are minimized down to 0.54 [H] and 0.89 [V] mm-mrad.

# Optical function of Double Loop Circulator

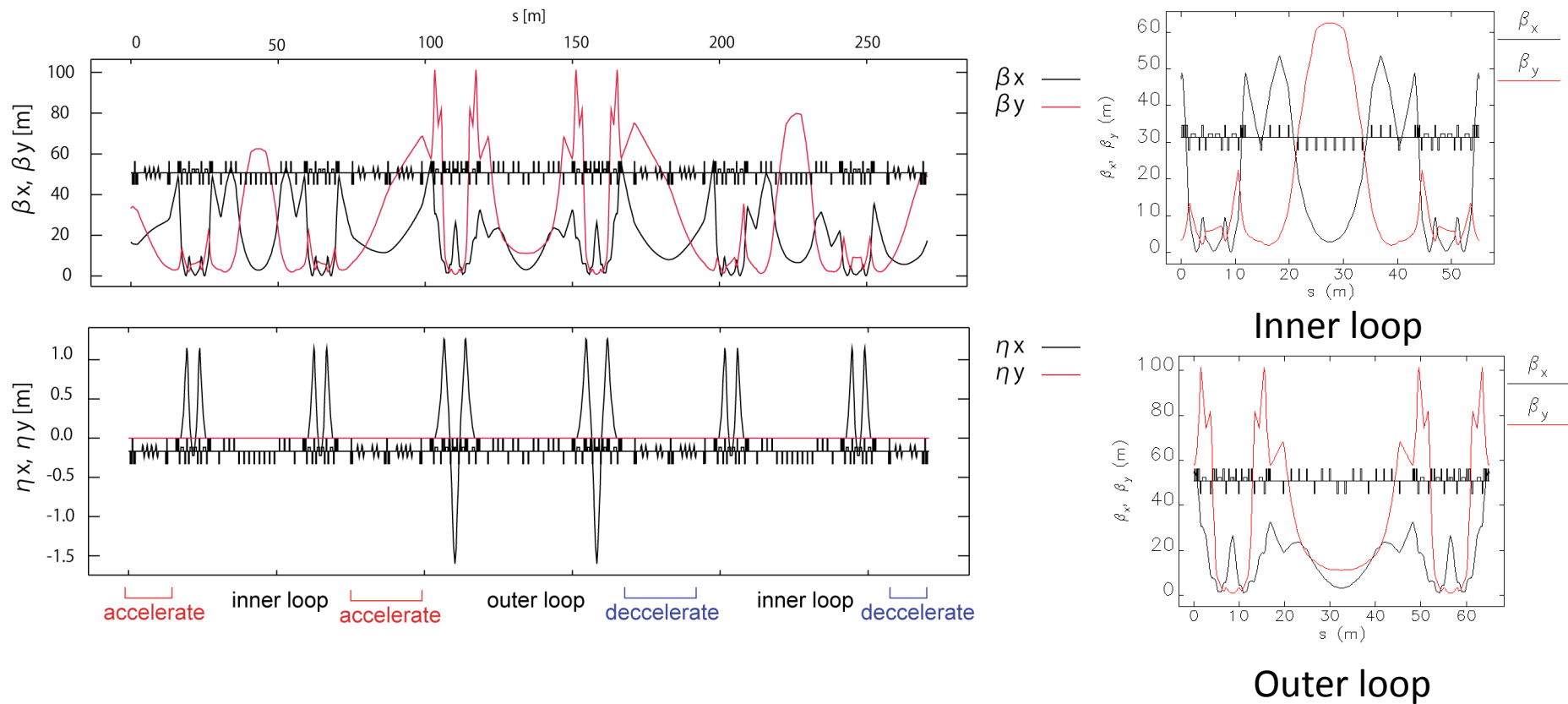

- Optical functions are quasi-symmetric.
- $\beta_x$  and  $\beta_y$  can be suppressed below 100 m in the whole circulator.
- Inner and outer loops are achromat and isochronous.

# Development of emittance

- $\varepsilon_{nx}$  increases step by step at every each arc.
  - In the first inner loop : 1 mm-mrad
  - In the outer loop : 5 mm-mrad
- The low emittance beam is difficult for 2 loop ERL compared with 1 loop ERL

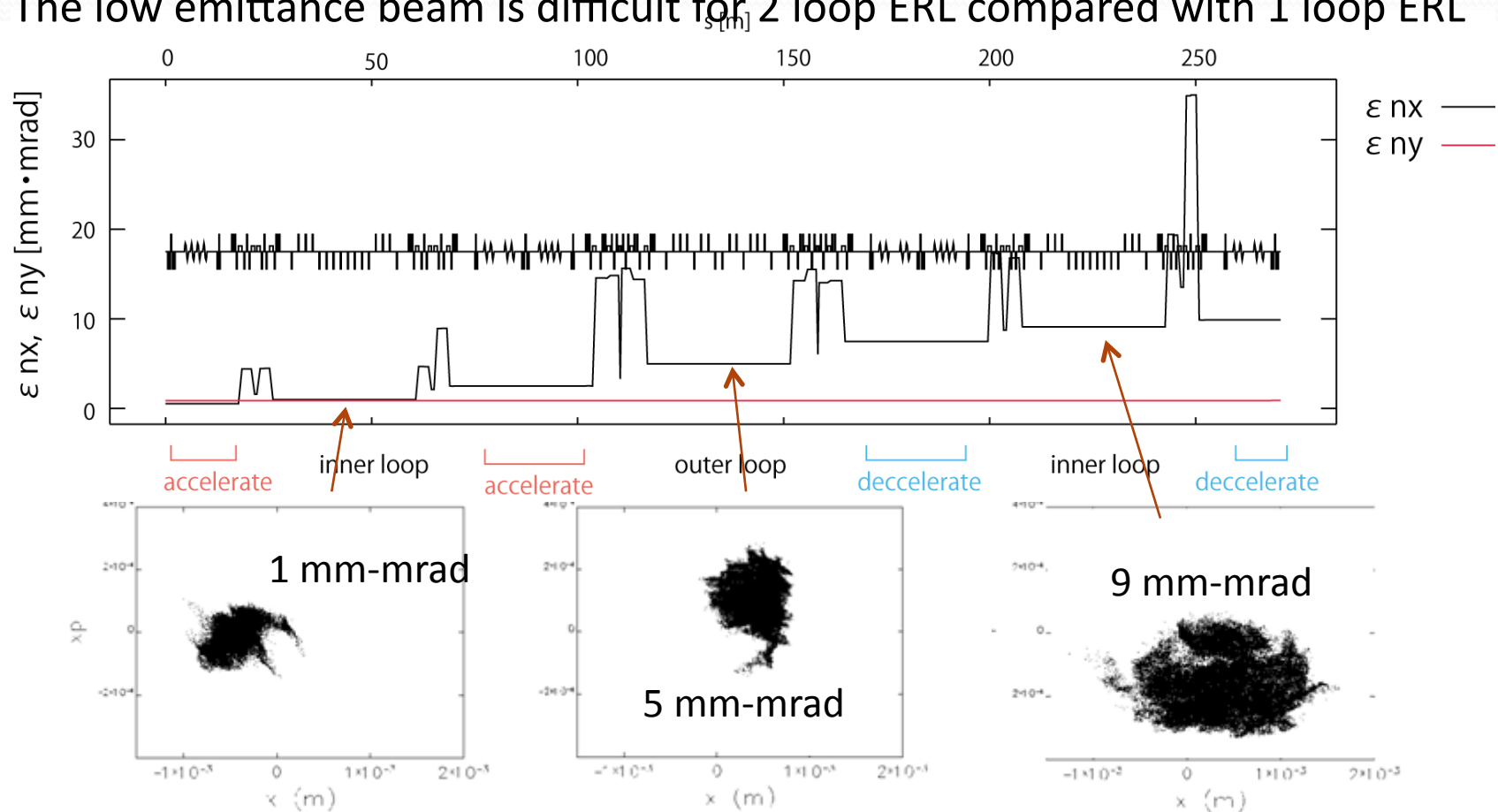



# Development of rms beam size

- Small  $\sigma_x$  and  $\sigma_y$  can be achieved at outer loop because of low  $\beta_x$  and  $\beta_y$ .

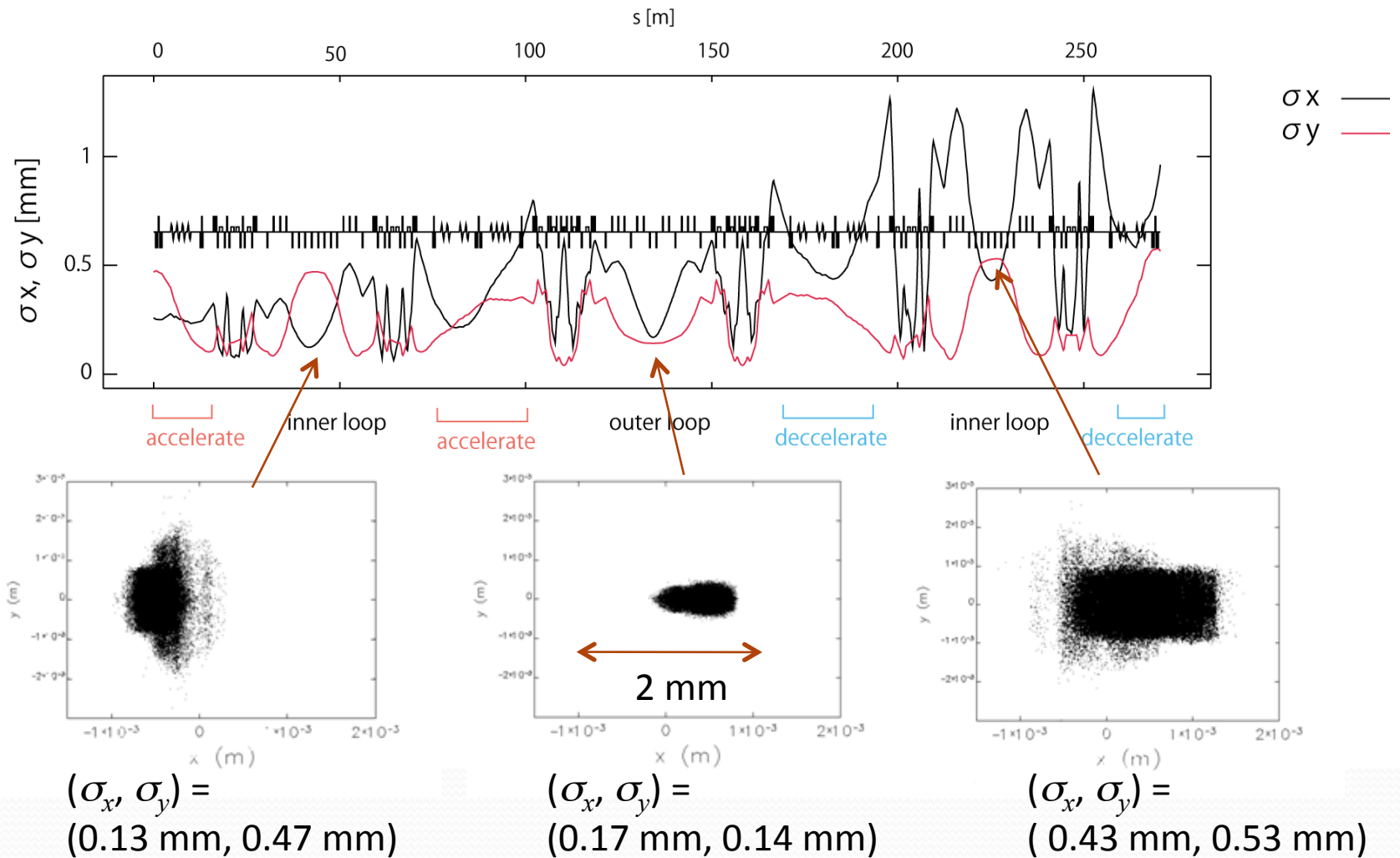

# Longitudinal phase space and distribution

125 MeV electron bunch just before the second deceleration

Longitudinal phase space

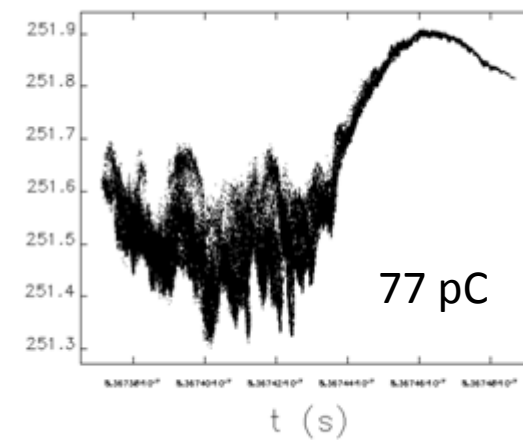
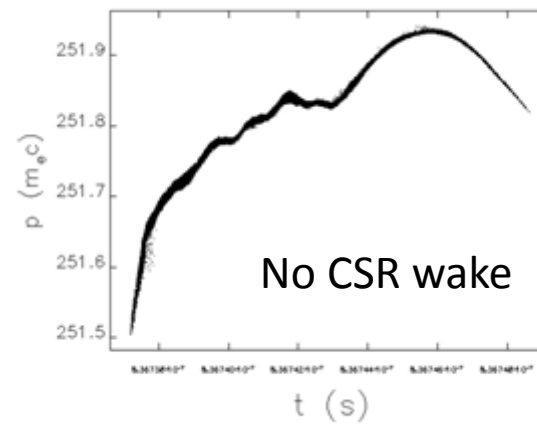

Histogram of the longitudinal distribution

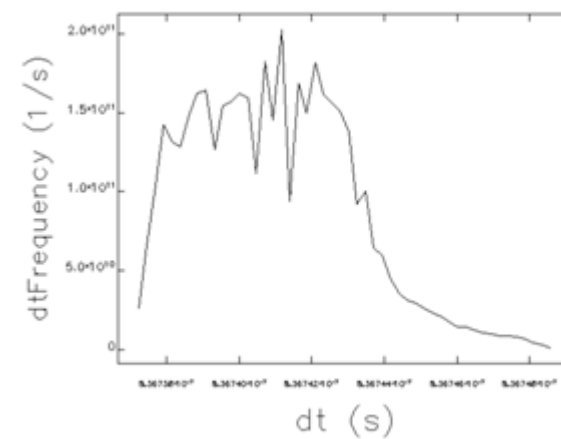
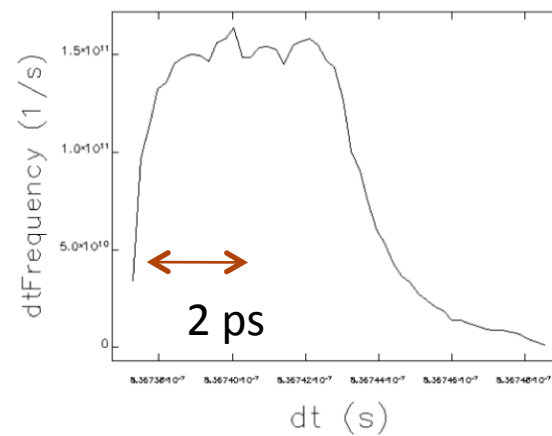

Modulation at the head of the electron bunch is enhanced due to the CSR wake.

# Space charge effect after energy recovery

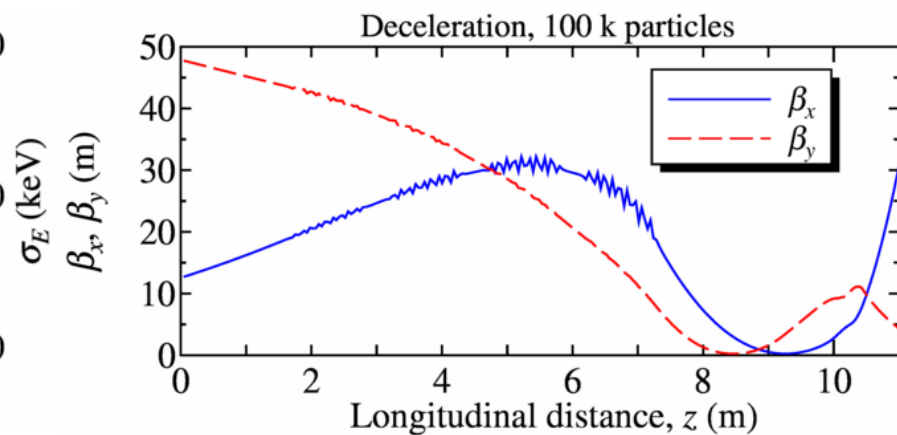
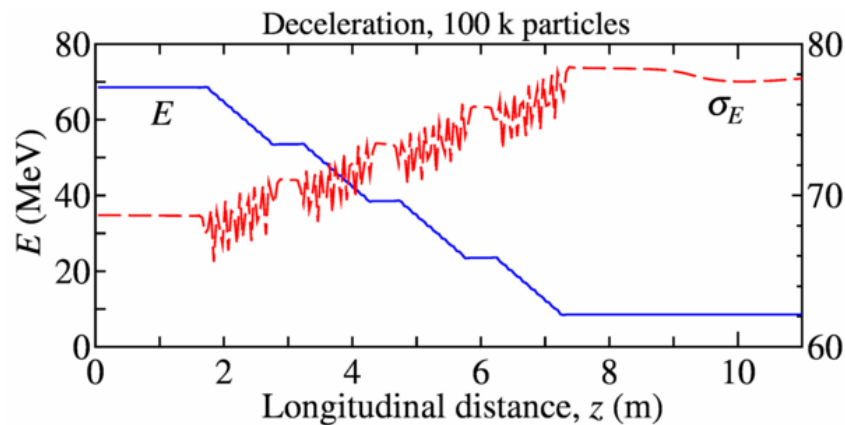
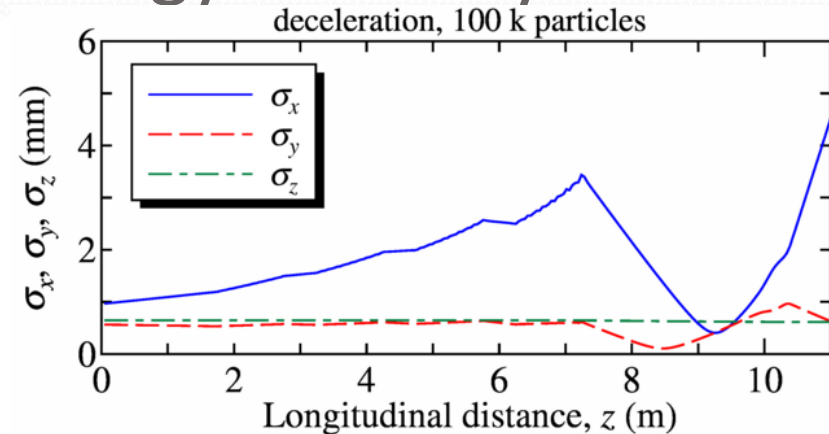
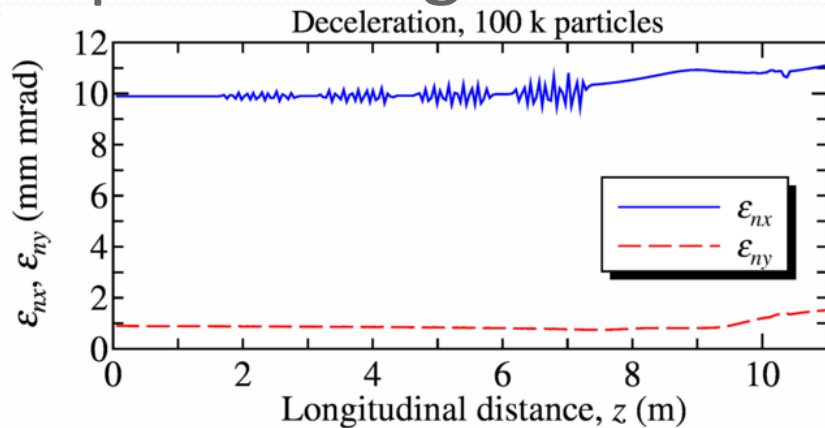

Maximum values of  $\sigma_x$  and  $\sigma_y$  are just before the extraction chicane :  
 $(\sigma_x, \sigma_y) = (4.1 \text{ mm}, 0.68 \text{ mm})$

The decelerated electron bunch can be transported to the dump with reasonable beam size.

## Distribution just before extraction chicane to the dump

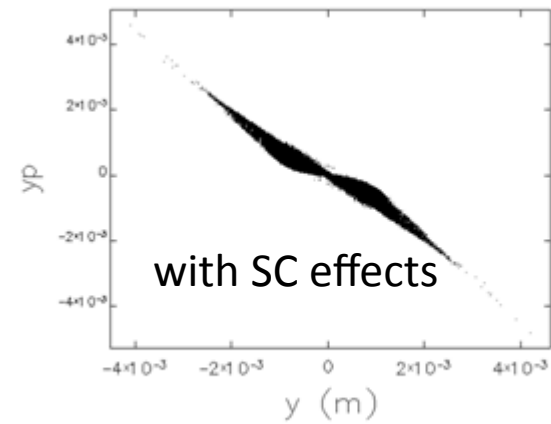
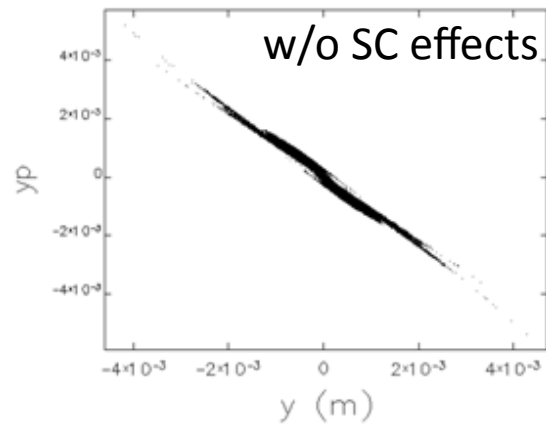
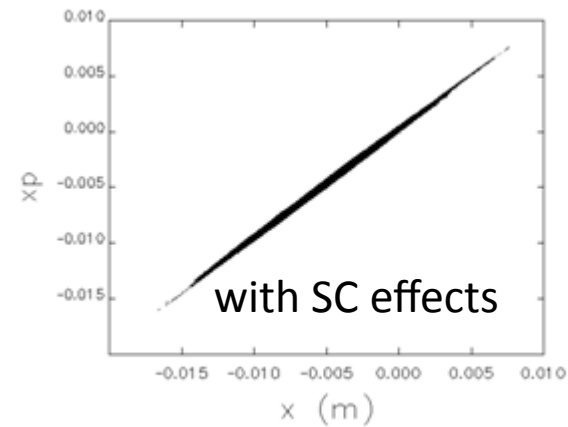
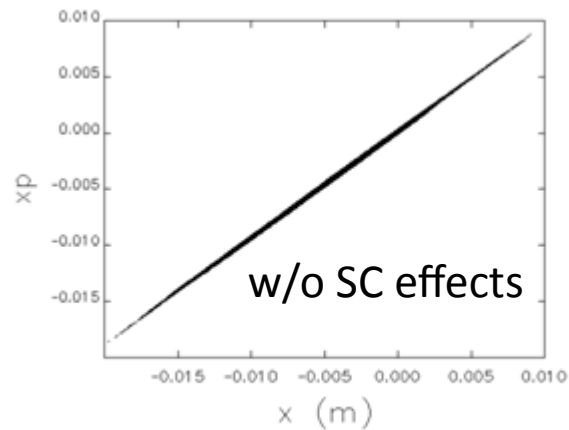

- SC effects increase  $\sigma_y$ ,  $\varepsilon_{nx}$ ,  $\varepsilon_{ny}$  by a few 10% but decrease  $\sigma_x$  from 5 mm to 4 mm.

# Summary

- The first trial of S2E simulation for the 2 loop cERL is reported.
  - GPT is used for low energy in the injector and deceleration, 'elegant' for high energy in circulator loops.
  - S2E simulation is need to be iterated for high performance.
  - Minimization of emittance and optical matching between injector and circulator are simultaneously performed.
  - Linear optics of double loop is optimized with a scheme of 'dummy loops'.
- It reveals the difficulty of maintaining the low emittance beam at 2 loop ERL compared to 1 loop.
  - First inner loop : 1mm-mrad ( Corresponding to single loop )
  - Outer loop : 5 mm-mrad (Corresponding to double loop )
- The decelerated electron bunch can be transported to the dump with reasonable beam size.
- Modulation at the head of the electron bunch is enhanced due to the CSR wake.