

250kV DC

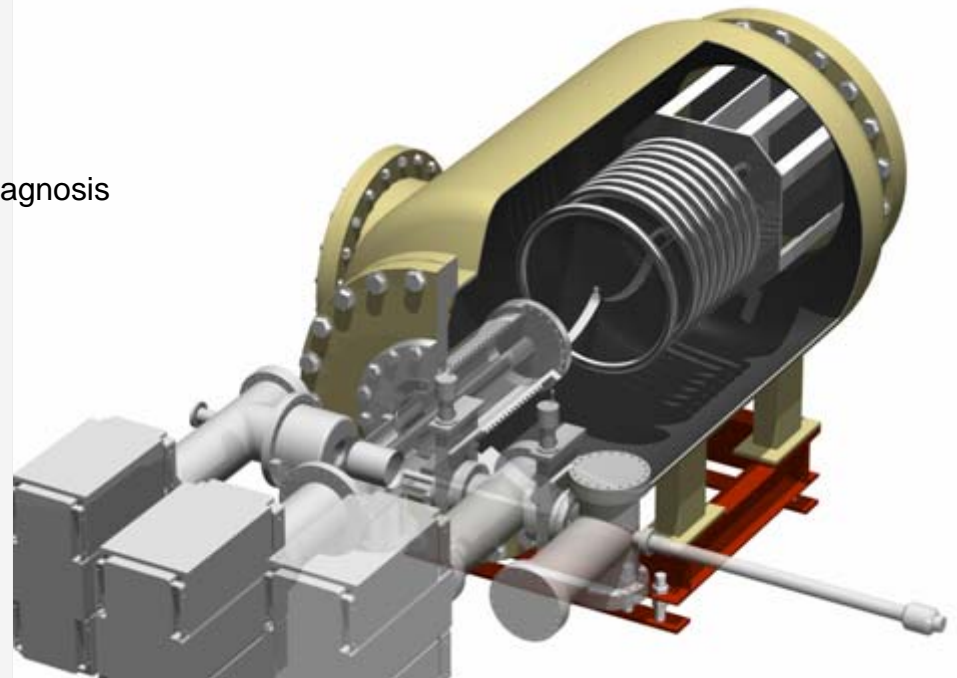

Cockcroft-Walton

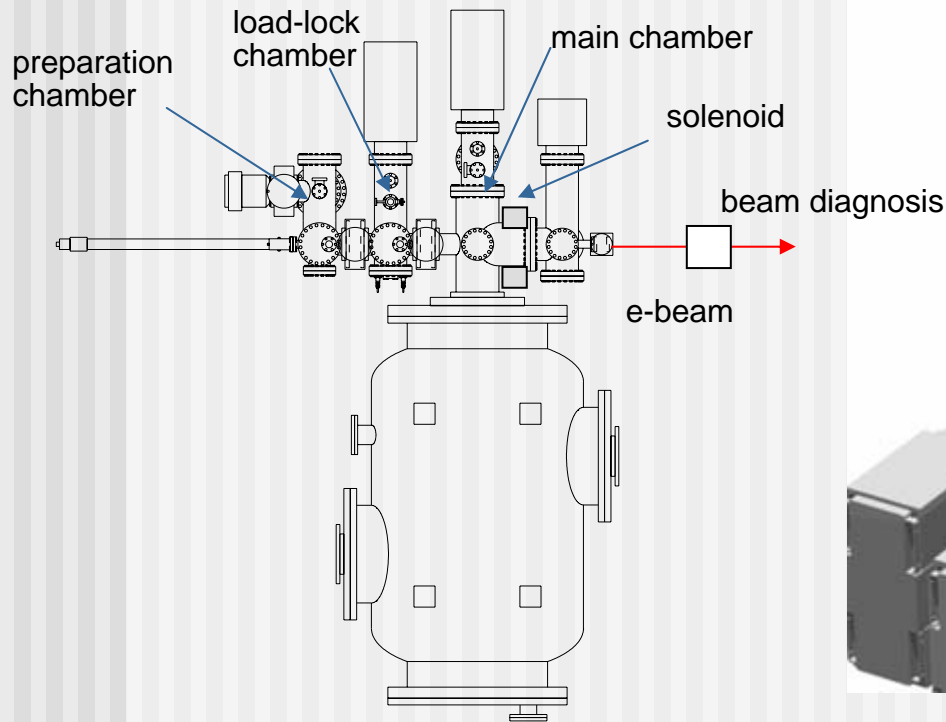
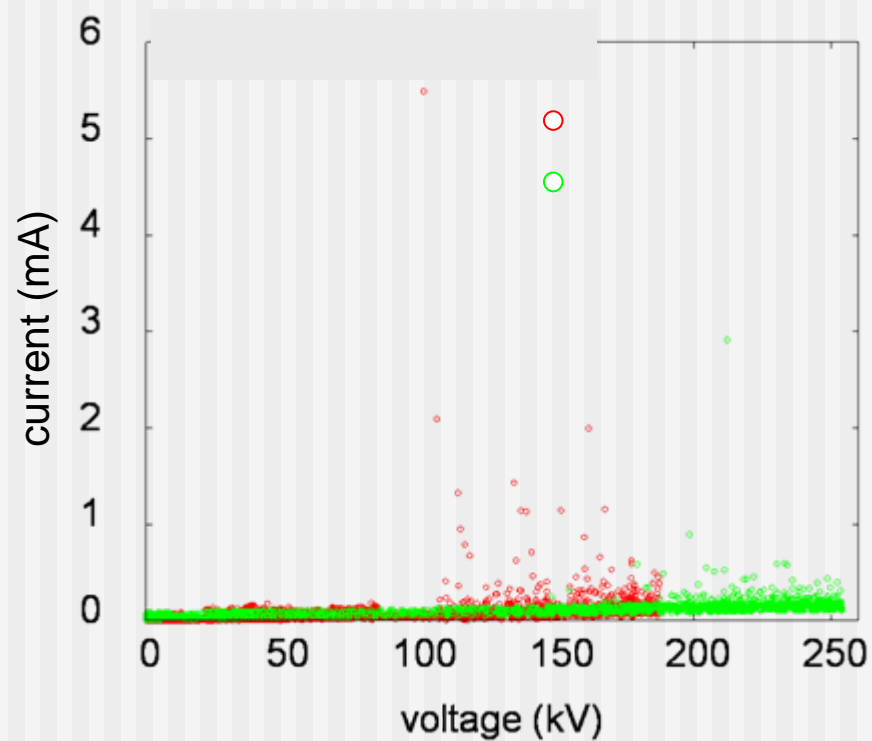
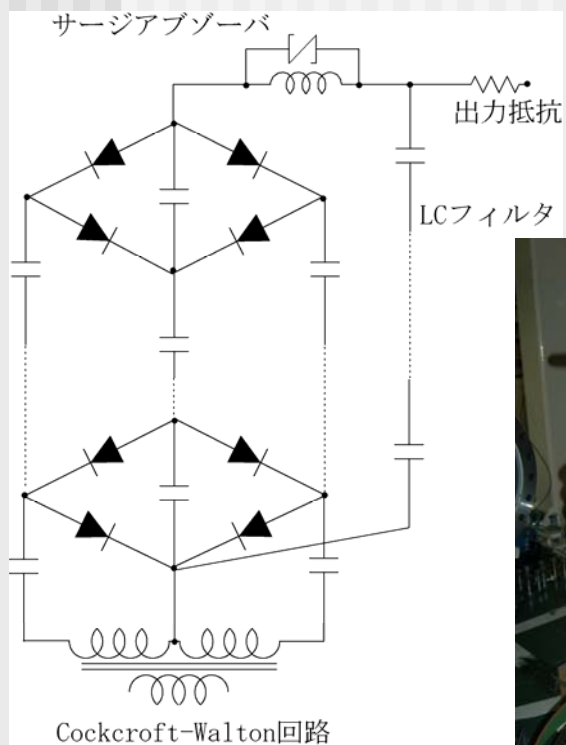

Cockcroft-Walton

	250kV-50mA	500kV-100mA
	20 kHz	40 kHz
	8.4 nF	16.8 nF
	6	12
	1.2 H	1.2 H
	1.4 nF	1.4 nF
	1.4×10^{-4}	1.7×10^{-5}
	1.9×10^{-4}	

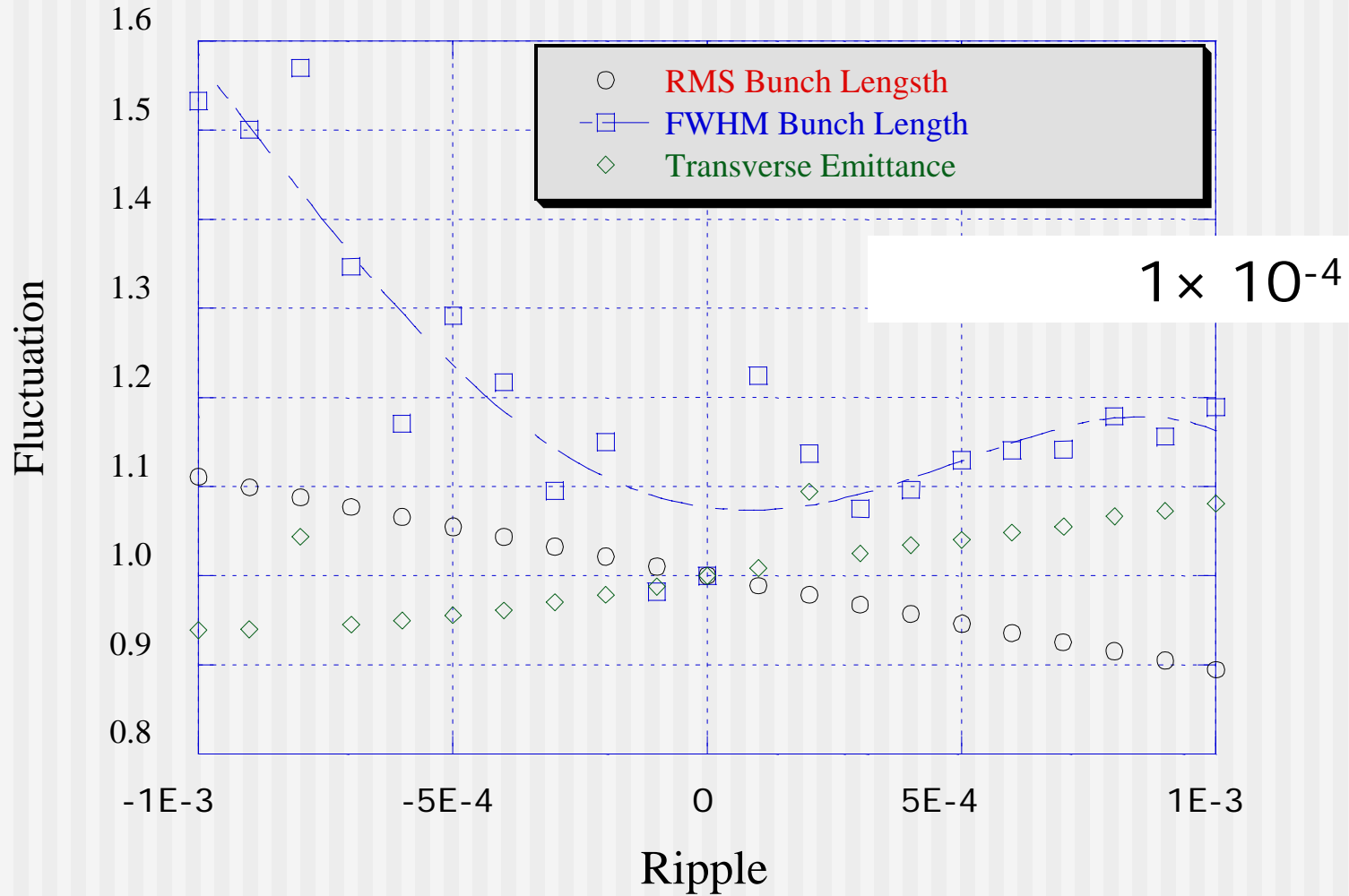

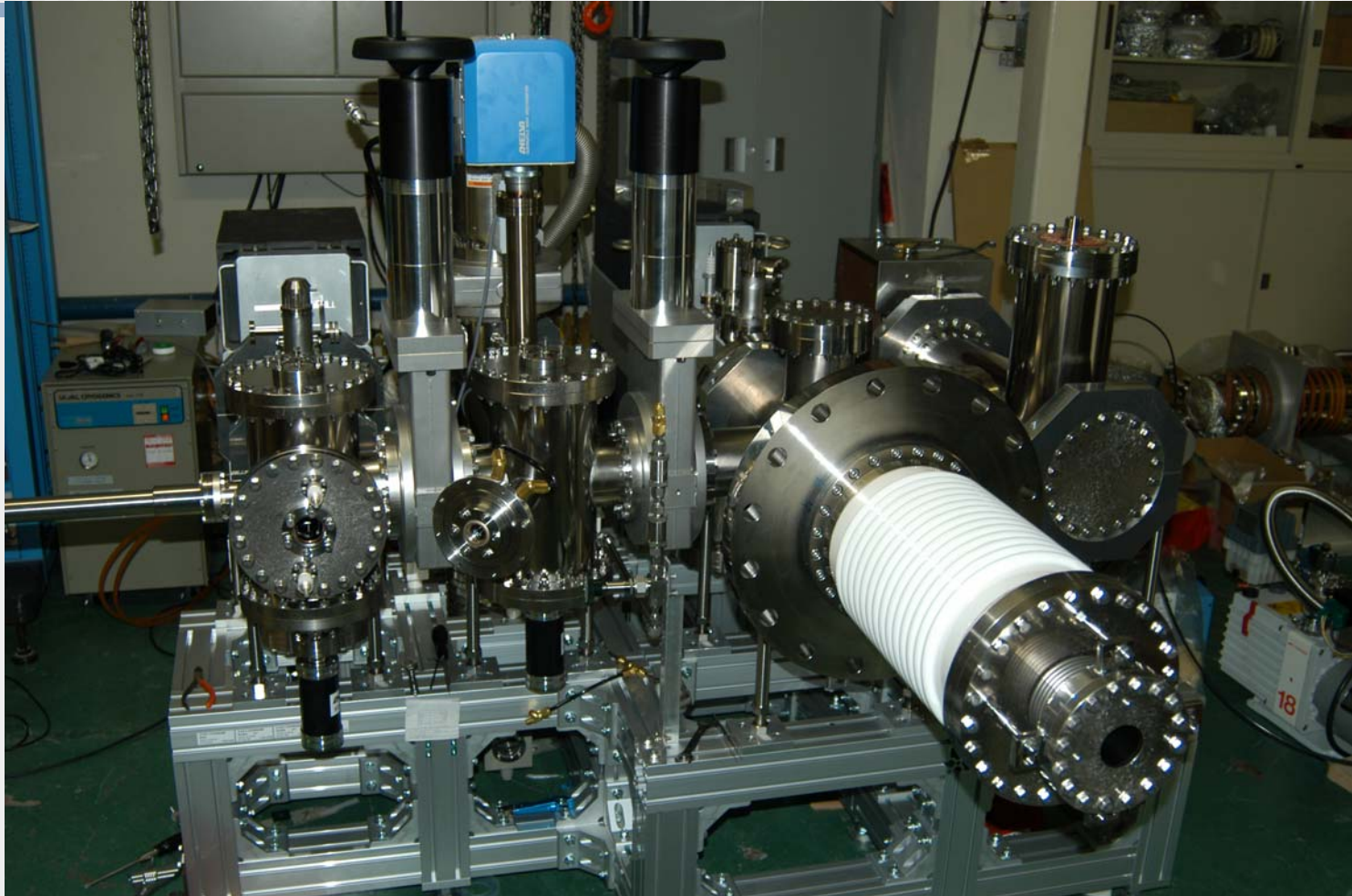

7 SUS
0.28m²

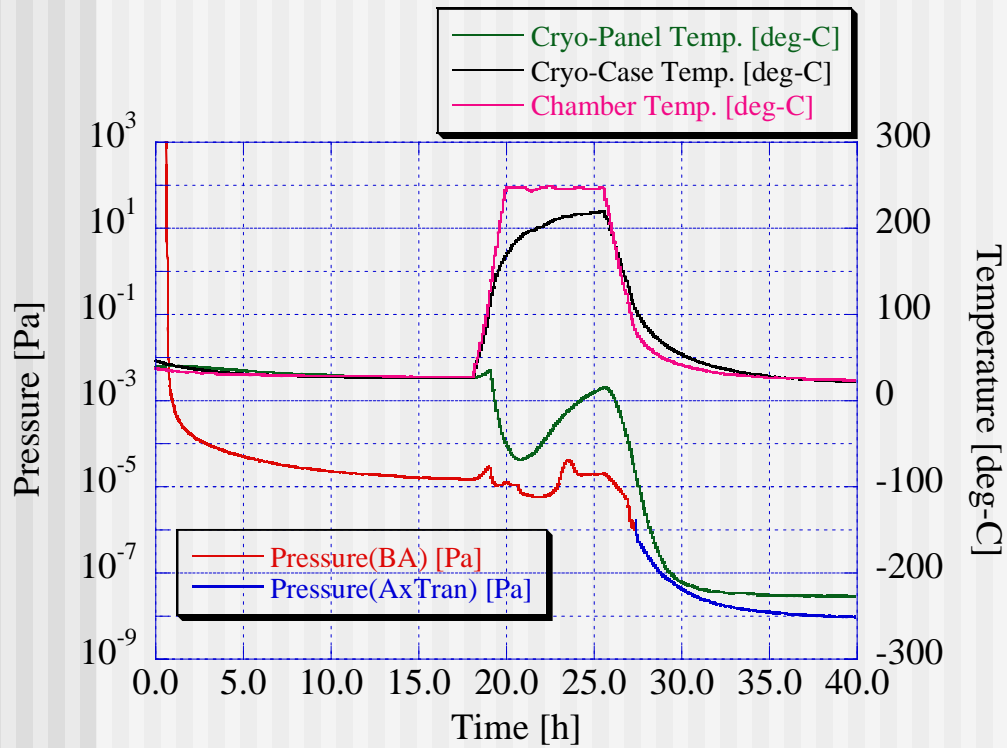

$< 1 \times 10^{-8} \text{Pa}$



40

NEA

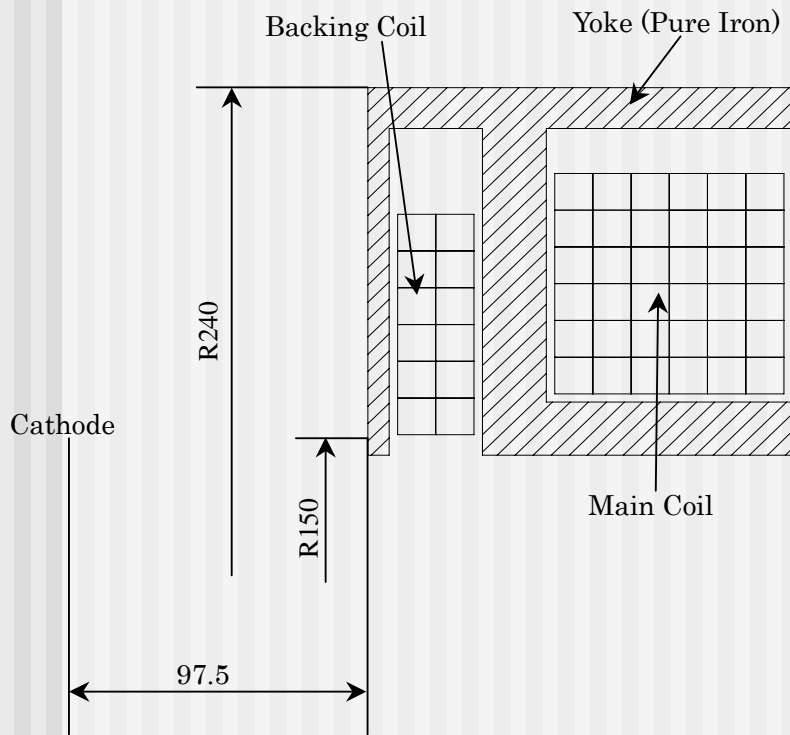

280A x 36 turn
: 1.32 T

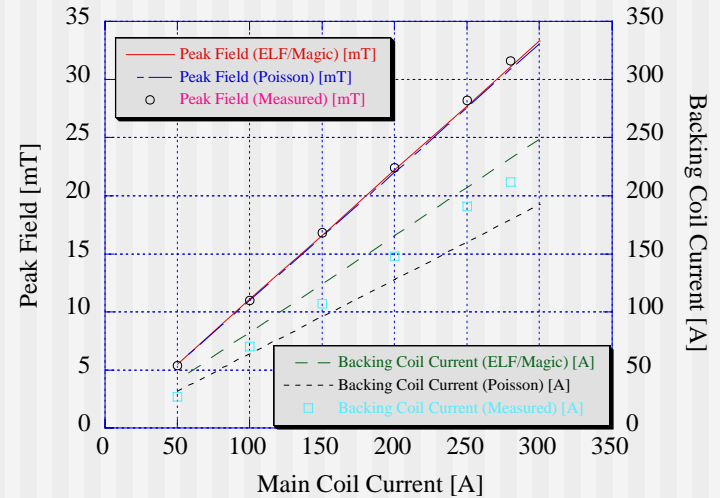
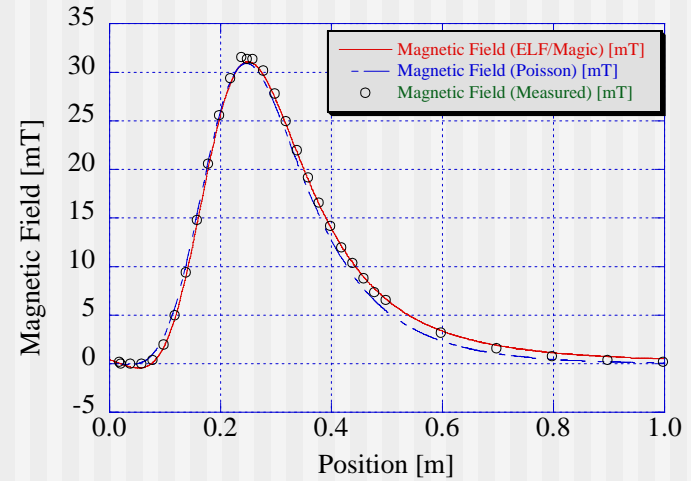

Parmela

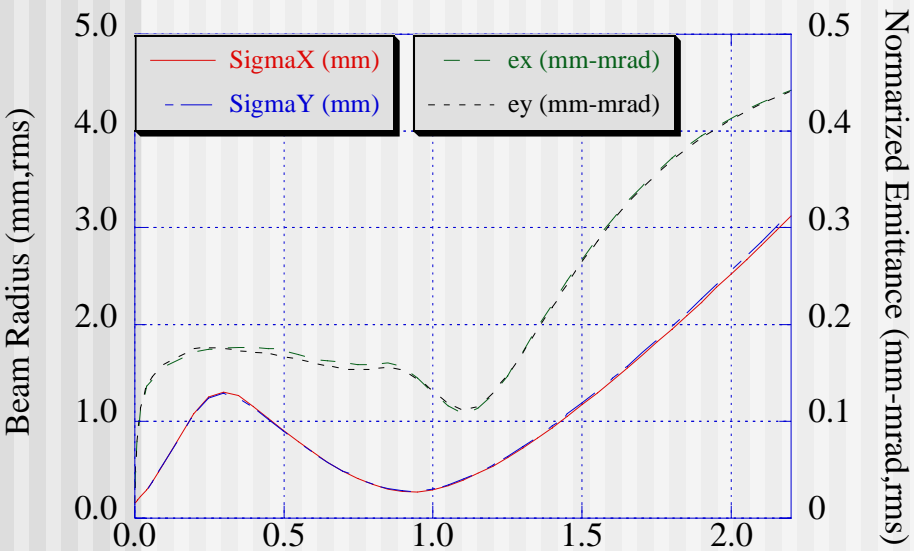

7.7pC \rightarrow B = 23.8mT, $\epsilon_n = 0.11$ mm-mrad

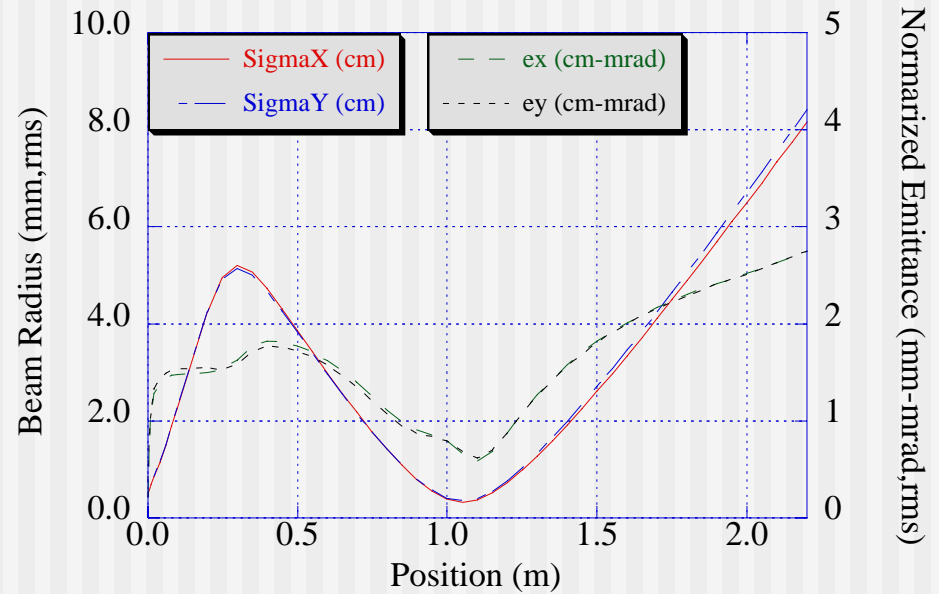

77pC \rightarrow B = 25.1mT, $\epsilon_n = 0.59$ mm-mrad

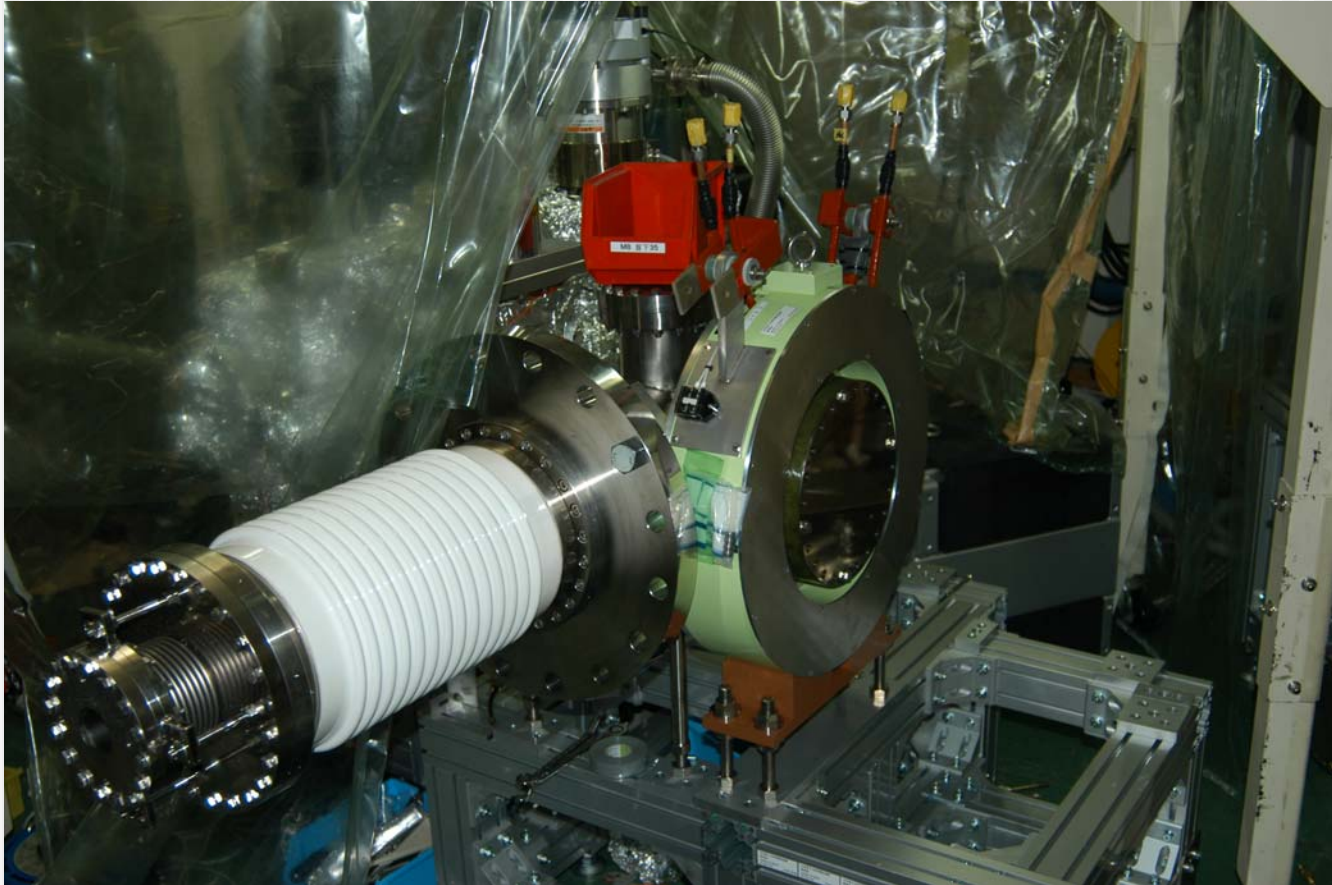

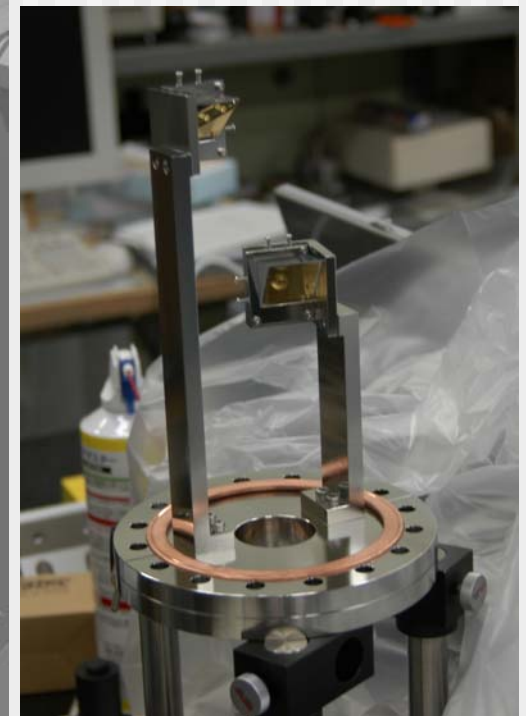
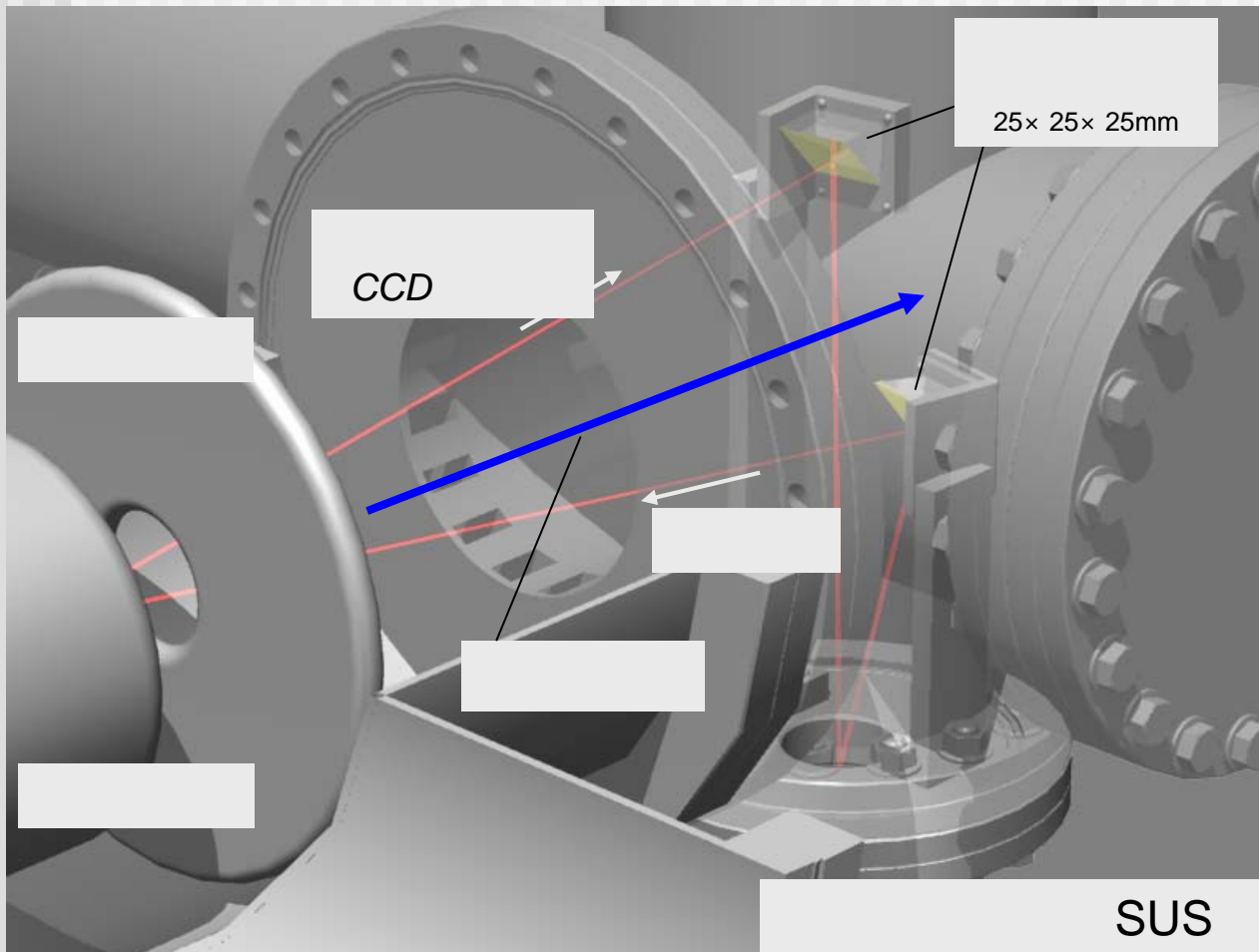

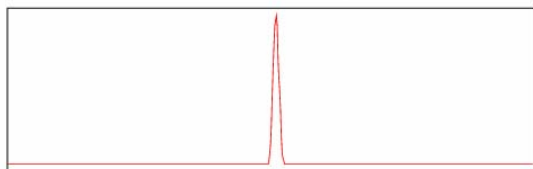
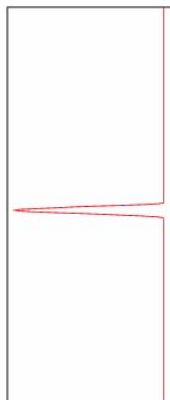
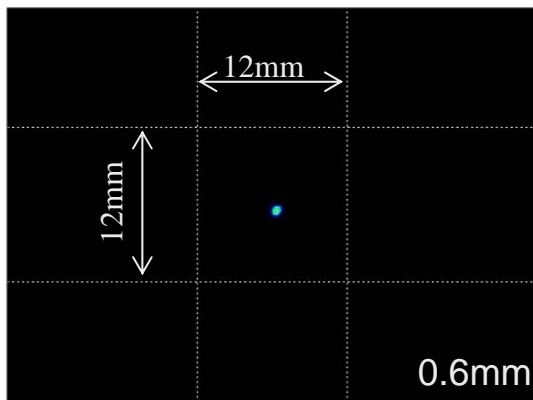

File Name:
 Acquisition time: Thu Jun 28 18:14:19 2007
 Horizontal
 Projected region 145 - 333
 FWHM 8
 Vertical
 Projected region 231 - 413
 FWHM 9

- He-Ne
- <math><2\text{mW}</math>
- 1

Off-lineでの集光テスト

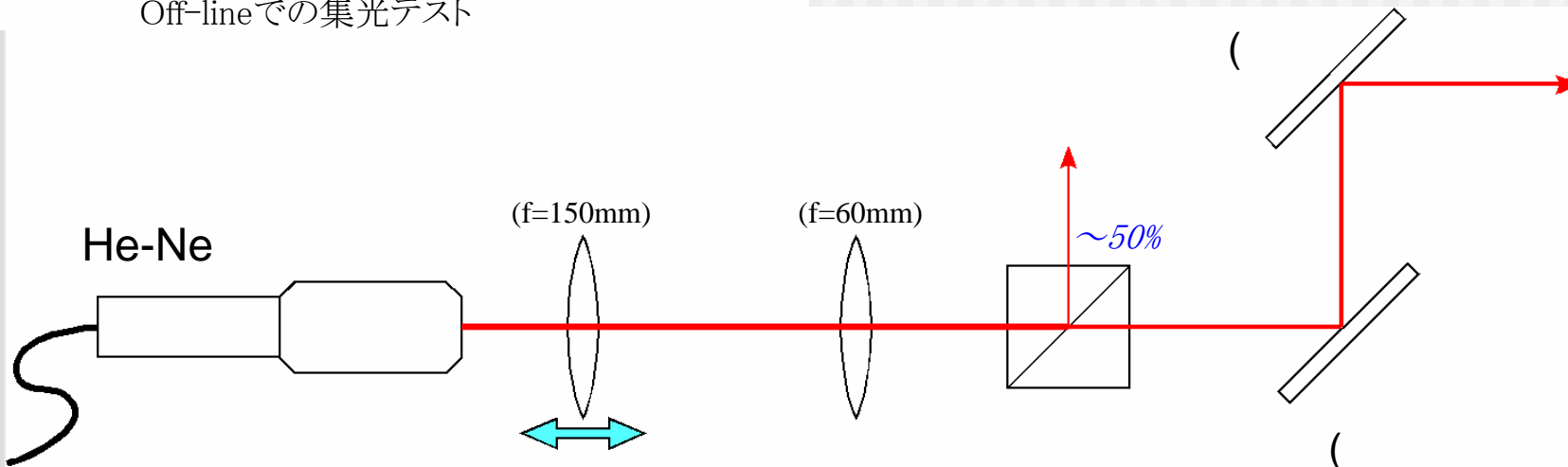

- 250kV DC

