

# DEVELOPMENT OF 2-CELL SC CAVITY SYSTEM FOR ERL INJECTOR LINAC AT KEK

S. Noguchi\*, E. Kako, M. Sato, T. Shishido, K. Umemori, K. Watanabe and Y. Yamamoto  
 KEK, 1-1, Oho, Tsukuba, Ibaraki, 305-0801, Japan

## Abstract

Development of a SC Cavity Injector Cryomodule for the compact ERL (cERL) [1] is being continued at KEK since 2006. Design of a cryomodule containing three 2-cell 1.3-GHz cavities is almost completed and will be ordered soon. Status of R&D and design details is reported.

## INTRODUCTION

An injector for cERL is required to accelerate a CW electron beam of 100mA to 10MeV. In this application, critical hardware components are not cavities but RF input couplers and HOM dampers. Several combinations of number of cavity and cells per cavity were examined, and a three 2-cell cavity system was chosen for cERL. Each cavity is drove by two input couplers to reduce required power handling capacity and also to compensate coupler kick. HOM coupler scheme was chosen for HOM damping, and 5 HOM couplers are put on beam pipes of each cavity. Because of simplicity cavities are cooled by jacket scheme. Basic parameters of the cavity are summarized in Table 1.

Table 1: Basic Cavity Parameters

|                         |                   |          |
|-------------------------|-------------------|----------|
| Frequency               | 1.3               | GHz      |
| Number of cell          | 2                 |          |
| R / Q                   | 205               | $\Omega$ |
| Operating Gradient      | 14.5              | MV / m   |
| Number of Input Coupler | 2                 |          |
| Coupler Power           | 167               | kW       |
| Coupler Coupling Q      | $3.3 \times 10^5$ |          |
| Number of HOM coupler   | 5                 |          |
| Operating Temperature   | 2                 | K        |

## CAVITY

A 2-cell cavity is shown in Figure 1. It has a TESLA-like cell shape and larger beam pipe aperture of 88mm. Two fully equipped prototype cavities were fabricated, and the first cold test in a vertical cryostat was done in the last March. The cavity gradient reached 30MV/m with small electron loading (Figure 2). The reason of low Q value is due to losses at beam pipe flanges made of stainless steel. During the test, we observed some thermal instability (blue dots in Figure 2), where both Q and gradient decrease slowly. It is well known due to the heating of pick-up antennae of HOM couplers. Heating of one HOM coupler was detected by thermometer at around 16 MV/m, but finally we could keep 16 MV/m for 6 hours.

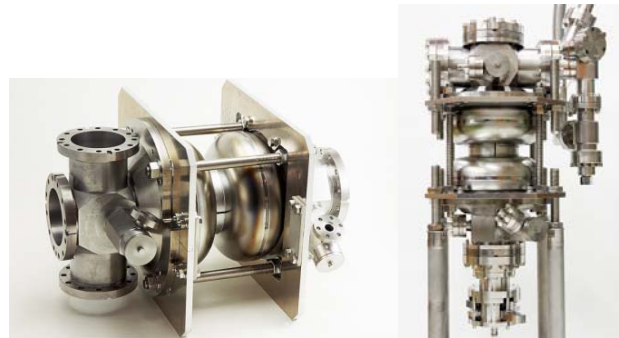
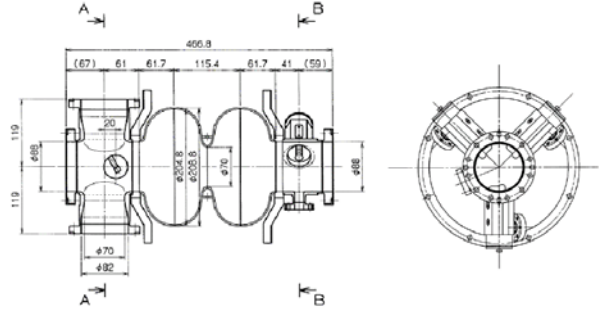

Figure 1: 2-cell Cavity

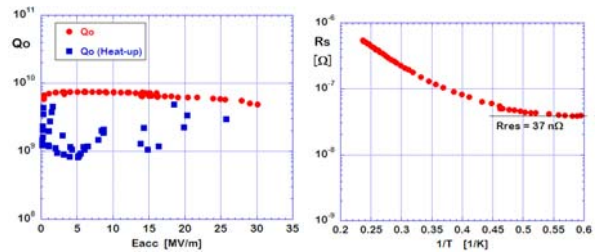

Figure 2: Vertical Test Results.

## INPUT COUPLER

RF input coupler is the most critical component in the high power application of the superconducting cavity. The most powerful CW coupler under operation is the KEK-B couplers, which has a coaxial disk type window developed for TRISTAN SC cavities [2]. We made scaled models to 1.3 GHz, as shown in Figure 3 and 4. Impedance of coaxial part is  $41\Omega$ , and the outer diameter is 82 mm.

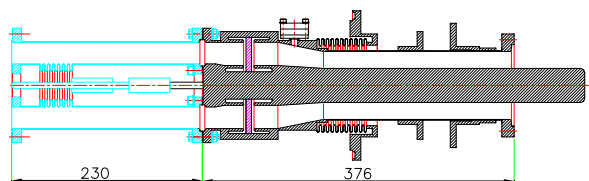

Figure 3: Input Coupler for Injector Cavities.

\* shuichi.noguchi@kek.jp

Couplers will be assembled to cavity in the clean-room before installation to a cryostat, so it should be short as possible. Then thermal intercept becomes difficult, and requires the 5k and 80k anchors at outer conductors. Inner conductors and the windows are cooled by water. High power test is scheduled in September.



Figure 4: Prototype Input Coupler

### HOM COUPLER

We decided to use HOM couplers instead of beam pipe HOM absorbers to damp HOMs, because absorbers are not well established in cold and they need extra drift space. Major HOMs are summarized in Table 2.

Table 2: Major HOMs

| Mode  | Frequency | R / Q              | Measured $Q_L$ |
|-------|-----------|--------------------|----------------|
| TE111 | 1.57GHz   | 0.59 $\Omega/cm^2$ | 400            |
|       | 1.63GHz   | 1.8 $\Omega/cm^2$  | 350            |
| TM110 | 1.80GHz   | 4.0 $\Omega/cm^2$  | 1000           |
|       | 1.88GHz   | 1.9 $\Omega/cm^2$  | 900            |
| TM011 | 2.28GHz   | 64 $\Omega$        | 2000           |
|       | 2.31GHz   | 12 $\Omega$        | 1600           |
| TM020 | 2.67GHz   | 0.4 $\Omega$       |                |
|       | 2.69GHz   | 31 $\Omega$        |                |

TESLA HOM couplers are considered as the best choice, but it is well known that thermal instability appears above 10 MV/m in the CW operation. It is also well known that heating happens at pick-up antennae of HOM couplers, but it is not yet understood why niobium antenna becomes normal conducting. One may expect that if the current density at antennae is reduced, the threshold gradient increases. TESLA HOM couplers are modified by introducing second stub and a boss as can be seen in Figure 5 [3].



Figure 5: Two Stub HOM Coupler

Figure 6 shows the H field distribution of the modified HOM coupler, the H field is reduced by a half, to 2000 A/m at 15 MV/m. The first cold test was performed with these HOM couplers. After some processing, we could raise the gradient to 30 MV/m. Heating appeared in one HOM coupler, but we could keep the gradient of 16 MV/m for 6 hours.

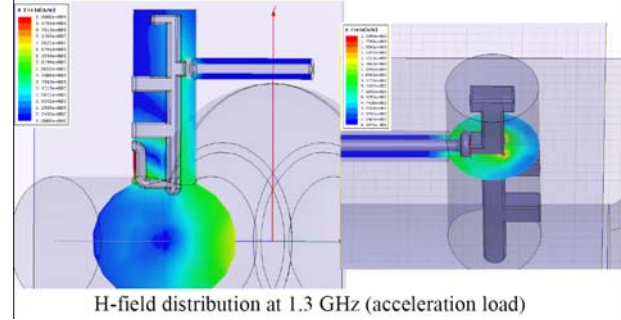

Figure 6: H-Field Distribution

### FREQUENCY TUNER

We will use Slide Jack tuners [4, 5] which are used in STF cavities as is shown in Figure 7. Two pairs of wedge are set on both side of jacket cylinder flanges and driven by one shaft from outside of a cryostat. One piezo system is put in series with a slide jack tuner, and will be replaceable from a cryostat opening. Stroke of the tuner is listed in Table 3.



Figure 7: Slide Jack Tuner

Table 3:

|                  | Type       | Stroke    | $\Delta f$ |
|------------------|------------|-----------|------------|
| Mechanical Tuner | Slide Jack | 1mm       | 1.3MHz     |
| Fine Tuner       | Piezo      | 4 $\mu$ m | 2.6kHz     |

### CRYOSTAT

Figure 8 and 9 show a cryostat containing three 2-cell cavities. All the cross section may become square. Cavities are dressed with He vessel made of Titanium, and magnetic shields are put inside of He vessel. The estimated cryogenic load in 100mA and 10MV operation is summarized in Table 4. As is seen from this table, it is critical to take dynamic load of input couplers and HOM extraction cables. They will be anchored to 4.5K reservoir

panels put on both side of cavities, which works as a thermal shield as well. Because of this difficulty the operating gradient may be lowered.

Table 4: Cryogenic Load per Cavity

|               | 2 K    |         | 4.5 K  |         |
|---------------|--------|---------|--------|---------|
|               | Static | Dynamic | Static | Dynamic |
| Cavity        | 0      | 6W      | 0      | 0       |
| Input Coupler | 2W     | 4W      | 8W     | 16W     |
| HOM Cable     | 1W     | 7W      | 5W     | 14W     |
| Beam Pipe     | 1W     | 0       | 2W     | 0       |
| Others        | 5W     | 0       | 10W    | 0       |
| Total         | 9W     | 17W     | 25W    | 30W     |

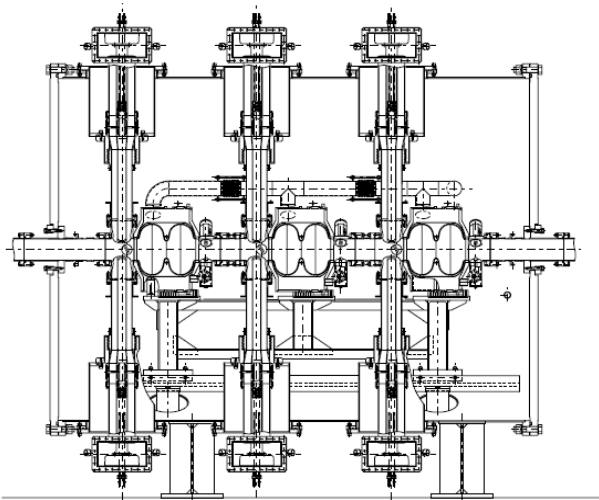

Figure 8: Injector Cryomodule

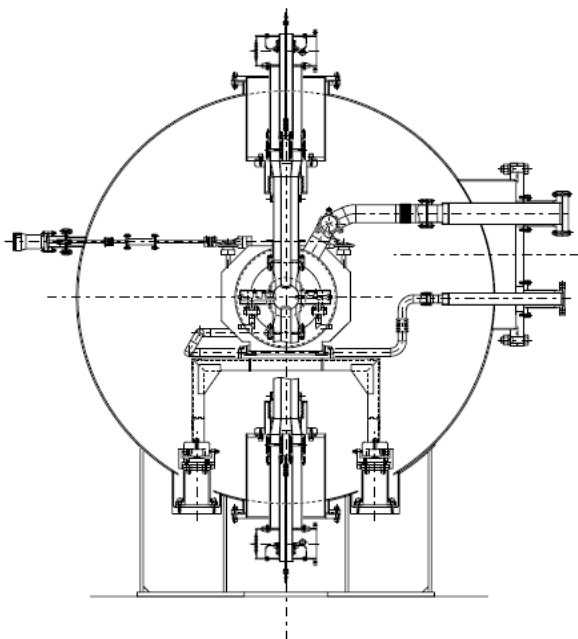

Figure 9: Injector Cryomodule

## SUMMARY

Development of Injector cryomodule is in progress. Assembly of cryomodule is scheduled in late 2011. Depending on test results, the number of cavities for the real ERL may be increased to 4.

## REFERENCES

- [1] S. Sakanaka, et al., in these proceedings, TU5PFP081.
- [2] S. Noguchi, et al., "Couplers-Experience at KEK", Proceedings of 4-th SRF Workshop, KEK, 1989, KEK Report 89-21, 1990, p397-p412.
- [3] K. Watanabe, et al., "New HOM coupler Design for ERL Injector at KEK", Proceedings of 13-th SRF Workshop, Peking University, Beijing, China, (2007).
- [4] E. Kako, et al., in these proceedings, TU3RAI04.
- [5] Y. Yamamoto, et al., in these proceedings, TU5PFP075.